



**FOX**  
robotics

# FoxBot Autonomous Forklift

## Installation, Operation, and Maintenance Manual

---



### Fox Robotics References

---

Manual #:	FoxBot-IOM-001
Revision Level:	0
Release Date:	March 2023

### TECHNICAL RELEASE LOG

Author	Rev	Modification	Date
Fox Robotics Inc.	0	Original Release	04/2021
Fox Robotics Inc.	1	2023 Update	03/2023

### IMPORTANT SAFETY INSTRUCTIONS



#### NOTICE

**SAVE THESE INSTRUCTIONS** – This manual contains important instructions that should be followed during installation, operation, and maintenance of this equipment.



#### NOTICE

Read this manual in its entirety before commencing work of any kind. Only qualified personnel who are well versed in all operational aspects of this equipment should install, operate, and maintain this equipment. All operators should abide by all applicable safety rules and practices contained herein.



#### ⚠ DANGER

Never use this equipment in any manner for which it was not designed. Improper use can severely impact user safety. Fox Robotics Inc. cannot be held liable for any damages resulting from such use. Failure to observe this label WILL result in death or serious injury.



**ALL RIGHTS RESERVED**  
**© COPYRIGHT 2021 by Fox Robotics Inc.**

This publication contains proprietary information and is the intellectual property of Fox Robotics Inc. (Fox Robotics). Neither this document nor any other information disclosed herein shall be reproduced or distributed in any form, for any purpose, without express written consent from Fox Robotics Inc.

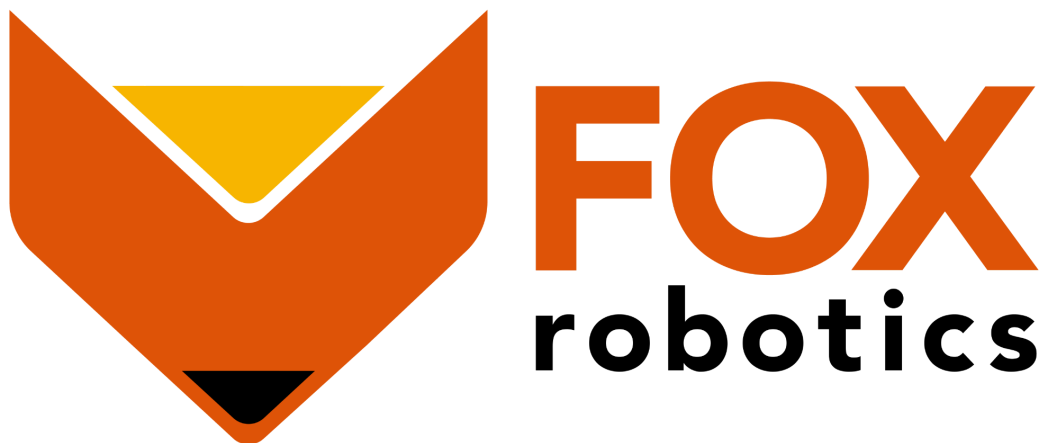

For immediate assistance with sales, service, or parts for this equipment contact:

Support:

+1 (512) 777-2898



**NOTICE**

The equipment serial number should be recorded below for future reference. The serial number can be found on the Data Plate (mounted on the equipment). Reference the serial number when contacting Fox Robotics Inc. for assistance.

Serial Number: \_\_\_\_\_

**Fox Robotics, Inc. (Fox Robotics)**

4101 Smith School Road, Bldg 2, Suite 100

Austin, TX 78744

[www.foxrobotics.com](http://www.foxrobotics.com)



## TABLE of CONTENTS

<b>1 Introduction</b>	<b>6</b>
1.1 Scope of this Manual	6
1.2 Operational Limitations	6
1.3 How to Use this Manual	6
1.4 Technical Documentation	6
1.5 Limited Warranty	6
1.6 Safety Awareness	8
1.7 Typical Safety Labels	9
1.8 Personal Protective Equipment (PPE)	10
<b>2 Unit Description</b>	<b>11</b>
2.1 Performance Data	12
2.2 Associated “Build-To” Standards	12
2.3 Features	12
2.4 Reference Material	12
2.5 Unit Components	13
<b>3 Shipping, Receiving, and Setup</b>	<b>17</b>
3.1 Shipping	17
3.1.1 Prepare the Robot for Transportation	17
3.1.2 Load the Robot	17
3.1.3 Secure the Robot	17
3.1.4 Secure the Batteries/Chargers	18
3.2 Receiving and Inspections	19
3.3 Required Site-Service Connections	19
3.4 Designate an Operational Area and Setup	20
3.5 Pre-Run Setup	24
<b>4 Pre-operational Inspections and Testing</b>	<b>30</b>
4.1 Visual Inspection(s)	30
4.2 Function Tests	30
<b>5 Operation</b>	<b>31</b>
5.1 Stack Light Descriptions	33
5.2 UPS and Battery System	34
5.2.1 Theory of Operation	34
5.2.2 To Isolate Power	34
5.2.3 To Restore Power	35
5.3 Safe Operation Parameters	35
5.4 FoxBot Start-Up	35
5.5 Manual Mode	35
5.6 Autonomous Mode - FoxLift App	36
5.7 Shutdown Procedures	41



5.8 Long-Term Deactivation	43
5.8.1 Outside Storage (exposed to the elements)	43
5.8.2 Inside Storage (protected from the elements)	43
5.9 Reactivation	43
<b>6 Maintenance</b>	<b>44</b>
6.1 Lock Out, Tag Out Procedure	45
6.2 Preventative Maintenance (PM) Schedule (General)	45
6.3 Troubleshooting	47
6.3.1 FoxBot Autonomous Forklift	47
6.3.2 Charging Station/Unit	48
6.4 Maintenance Procedures	49
6.5 General Precautions	49
6.5.1 Battery Charging	49
6.5.2 Parking Brake	49
6.6 Post Maintenance Results	50
6.7 Results and Witness Sign-offs	50
<b>7 Drawings and Bills of Materials</b>	<b>52</b>
7.1 Drawing List	52
<b>8 Appendix</b>	<b>57</b>
8.1 Terms and Abbreviations	57
8.2 Inspection, Tests & Maintenance Logs	58
8.2.1 Daily Inspections	58
8.2.2 Daily Function Tests	58
8.2.3 Weekly Inspections	58
8.3 OEM Forklift Specifications   FBCS14N	59
8.4 OEM Forklift Operation and Maintenance Manual	63



# 1 Introduction

## 1.1 Scope of this Manual

In accordance with ANSI B56.1 (7.2.1) and B56.5, this manual has been developed to guide the user in the safe operation of this FoxBot Autonomous Forklift (FoxBot). The manual is divided into several logically-ordered sections for ease of use. The scope of material included in this manual is limited to account only for specific operations and recommended procedures considered to be routine. The intent of this manual is to guide the operators and service technicians in the basic setup, operation, and maintenance of this equipment. This manual is NOT provided as a reference on mechanics, electronics, or hydraulics.

## 1.2 Operational Limitations

This manual is provided as a guide for most normal operations and the care and proper operating specifications of the equipment. Due to the varying environmental conditions and the nature of equipment operation, it is not possible to account for every possible unknown variable. Therefore, it is requested that when situations arise outside of the scope of this publication, operators should contact Fox Robotics directly for further assistance. Fox Robotics reserves the right to make design changes without incurring any obligation for the equipment or manual previously delivered.

## 1.3 How to Use this Manual

To the extent it is practical, this manual will cover all of the additions and components added to the base model forklift. For specifics on the base model forklift and other system components, see the [Appendix](#) for the specific [OEM Manual](#).



### NOTICE

**Certain OEM User Manuals have been provided by Fox Robotics as a courtesy to our customers. Fox Robotics, however, does NOT maintain these OEM Manuals and therefore, cannot speak to the accuracy or version(s) of those manuals. If in doubt about any of the provided OEM Manuals, please visit the respective OEM's website for the most current version(s) of their manuals.**

## 1.4 Technical Documentation

All information contained in this manual has been reviewed and approved by Fox Robotics engineering management. In addition, all information in this manual is based on the latest production information available at the time of the manual release. No disclosure, distribution, or reproduction of this material may be made without prior written authorization from Fox Robotics Inc.

## 1.5 Limited Warranty

Fox Robotics Inc. warrants that each unit sold shall, at the time of shipment (i) conform to applicable specifications and (ii) be free of defects in material and workmanship during normal and ordinary use and service (the "Warranty"). For specific client warranty information, refer to the relevant Supplier Agreement or Purchase Order (PO).





## 1.6 Safety Awareness

Safety is **YOUR** responsibility and must be of primary concern. Knowing the guidelines covered in this manual will greatly improve your ability to safely install, operate, and maintain this equipment. Promote good safety around the equipment and throughout all phases of operation. It is the equipment owner's/operator's responsibility to establish good safety measures, including equipment and personnel training, as well as strict enforcement of safety policies. Only qualified personnel, who are well versed in safety procedures and all operational aspects of this equipment, should install, operate, and maintain this equipment. ***Safety summaries and safety procedures can never replace good common sense. Be aware of your surroundings at all times.***

### Personnel Involvement

- **ENSURE** that all involved personnel have been successfully instructed on the operational hazards this equipment presents prior to commencing work.
- **ENSURE** all involved personnel are wearing proper Personal Protective Equipment (PPE), as applicable.
- **ENSURE** that all uninvolved personnel are cleared from the area during operation.
- **ALL** personnel should keep all loose items (clothing, rags, jewelry, etc.) and long hair away from moving/rotating parts.
- Do **NOT** operate this equipment if you are not professionally trained in its use.
- Do **NOT** operate this equipment if you are under the influence of alcohol or drugs (illegal or prescription).

### Area Awareness

- **ALWAYS** be aware of your surroundings when using this equipment.
- **NEVER** allow personnel to go underneath a lifted load.
- **NEVER** lift loads over personnel.
- **NEVER** enter a box trailer without properly securing the trailer (with chocks or a dock lock, for example).
- Do **NOT** operate this equipment in poorly lit environments or with limited visibility.



## NOTICE

**It is the user's responsibility to ensure that the operating area is sufficiently lit for operators, per ANSI/IES RP7. This requirement is for the benefit of the operator, not the robot. The robot is equipped with lighting for its own benefit and for the benefit of a manual operator.**

- Do **NOT** operate this equipment on unstable ground.
- Do **NOT** operate this equipment on slopes or grades in excess of 15%.

### Lifting Operations

- **ALWAYS** inspect and use adequately rated wooden/plastic pallets for every lift.
- **ALWAYS** use proper lifting techniques for every lift.

### Equipment Operation

- Do **NOT** use this equipment in a manner for which it was not specifically designed.
- Do **NOT** exceed the rated performance/capacity of this equipment.
- **ENSURE** that all safety/warning labels are present and obeyed.
- Do **NOT** remove (or bypass) any safety guards and/or warning labels/stickers from this equipment.





- **ENSURE** that this equipment has been isolated from its power source (electrical, etc.) and that any residual power is bled/drained prior to performing maintenance.



### 1.7 Typical Safety Labels

Labels are provided for a variety of safety-related and/or equipment operational reasons. Some reasons may be more serious than others, but **ALL** labels should be observed, read, and fully understood. Below are typical examples.



**⚠ DANGER**

Indicates a hazardous situation that, if not avoided, **WILL** result in death or serious injury.



**⚠ WARNING**

Indicates a hazardous situation that, if not avoided, **COULD** result in death or serious injury.



**⚠ CAUTION**

Indicates a hazardous situation that, if not avoided, **COULD** result in minor or moderate injury.



**NOTICE**

Provided to inform personnel of helpful information and identify potential damage to equipment. This label is not related to personal injury or hazardous conditions.



**👉 STOP**

Provided to alert personnel that important instructions will follow. Typically, these labels will fall directly after or just prior to mission-critical tasks. This can also be used to indicate a good place for a team meeting to occur to discuss the completed task(s) or upcoming tasks.

### 1.8 Personal Protective Equipment (PPE)

All personnel should wear suitable Personal Protective Equipment (PPE), when applicable and as instructed by their site safety guidelines and/or as conditions dictate.

Protection				
 Protect the Head	 Protect the Eyes	 Protect the Ears	 Protect the Hands	 Protect the Feet



## 2 Unit Description

The FoxBot Autonomous Forklift is an autonomous, self-driving forklift engineered and designed to unload semi-truck box trailers with minimal or limited human interaction.

It can be operated in one (1) of two (2) modes: Autonomous or Manual.

In Autonomous mode (without an onboard operator) the FoxBot requires minimal setup and then can be set free to do its work. In Manual mode, the FoxBot can be driven by an onboard operator that controls the FoxBot using local controls, much like a standard forklift.

The FoxBot Cabin (Cab) area can accommodate a single user, in the vertical (standing up) position. All controls are positioned well within the operator's line of sight and are easily manipulated/functioned.

The FoxBot is battery-powered and will hold a charge for approximately eight (8) hours, under general workload. Battery life may vary substantially with the level of use.

In Autonomous mode, the FoxBot can be controlled and monitored remotely, if necessary. There are five (5) Emergency Stop (E-Stop) buttons located around the FoxBot in case an emergency situation arises. Additionally, there are other sensors that constantly monitor real-time operating conditions of the FoxBot, such as sensor connection, battery power, and loss of power.



Figure 1 – FoxBot Autonomous Forklift (FoxBot)



## 2.1 Performance Data

For additional Forklift Specifications see ([8.3 OEM Forklift Specifications | FBCS14N](#)), in the Appendix of this manual.

<b>Model:</b>	Mark II
<b>Rated Capacity:</b>	3,000 lbs.
<b>Net Weight:</b>	7,189 lbs. (3,260 kg) ± 5% / excluding Battery
<b>Load Center Distance:</b>	24 in (600 mm)
<b>Power Source:</b>	Battery (36V)
<b>Battery Weight:</b>	<b>Min:</b> 2,300 lbs. (1,045 kg)   <b>Max:</b> 2,600 (1,182 kg)
<b>Hour Rate:</b>	6 hour
<b>Controls:</b>	Local & Remote/Autonomous
<b>Temp Limitations:</b>	34°F (1°C) to +104°F (+40°C)
<b>Towing Rating:</b>	NO TOWING*

\* The FoxBot is not rated to tow loads. If needed, the FoxBot may be towed a short distance. Contact support for guidance if towing is required.

## 2.2 Associated “Build-To” Standards

<b>ANSI B56.1</b> Safety Standard for Low Lift and High Lift Trucks	<b>ANSI B56.5</b> Safety Standard for Guided Industrial Vehicles	<b>UL 583</b> Electric-Battery-Powered Industrial Trucks
Part III	Part III	For Type “E” Industrial Trucks

## 2.3 Features

- Self-driving technology
- 360° safety-certified sensing
- Light Detection and Ranging (LiDAR)
- Active stereo depth camera
- Real-time pallet detection and localization
- Redundant encoder and position sensing
- No IT or WMS integration required
- Fewer employees in harm’s way
- Installs in just 30 minutes (Pick and place zones can easily be configured, allowing for flexibility in resource allocation and use).

## 2.4 Reference Material

### Appendix

- [8.3 OEM Forklift Specifications | FBCS14N](#)
- [8.4 OEM Forklift Operation and Maintenance Manual](#)



## 2.5 Unit Components

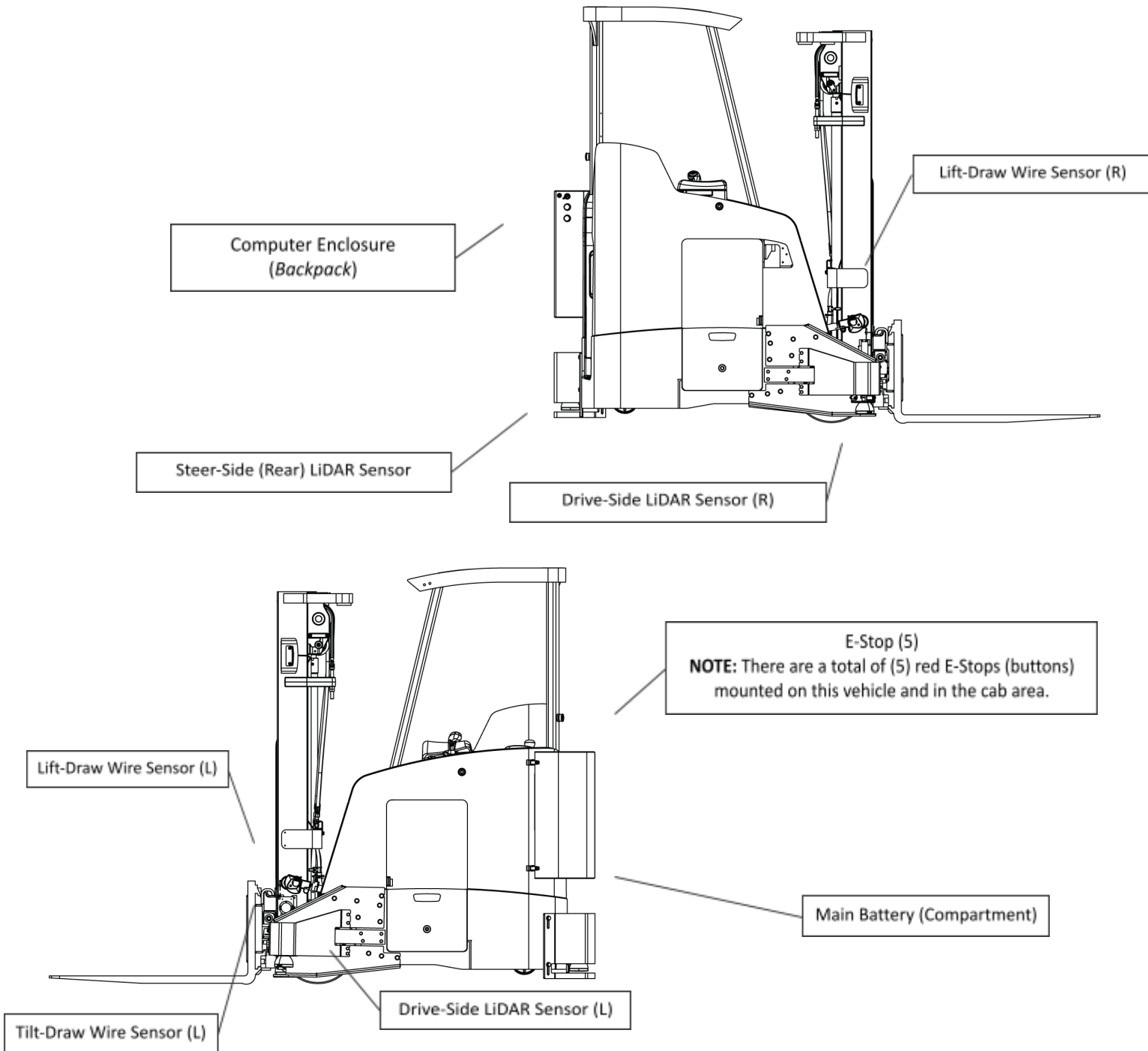

Figure 2 – Complete FoxBot Assembly (Side Views)



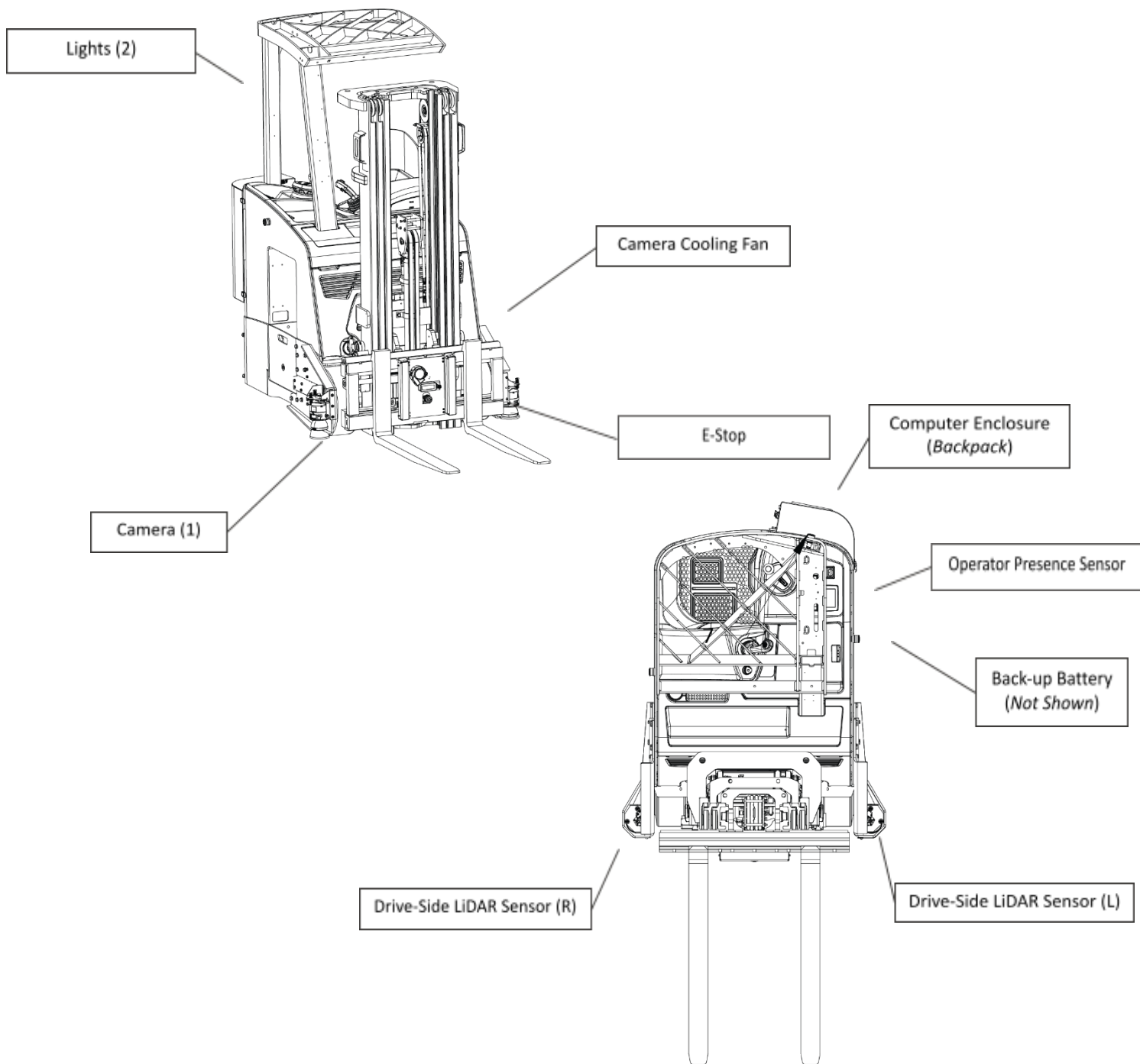

Figure 3 – Complete FoxBot Assembly (Front & Top Views)





Figure 4 – FoxBot Computer Enclosure



- 1) The “Mode Selector” switch puts the FoxBot in either Autonomous or Manual mode.
- 2) The “Home” Button brings everything into the start/run position for Autonomous mode.
- 3) The “Reset” Button clears all previous states and readies the FoxBot for new input.
- 4) The “Safety Bypass Switch” disables autonomous mode and allows the robot to drive at severely reduced speeds, even if E-Stop switches have been damaged.





## 3 Shipping, Receiving, and Setup

### 3.1 Shipping

If shipping the FoxBot becomes necessary, it should be prepared, loaded, and secured according to the directions below.

#### 3.1.1 Prepare the Robot for Transportation

- Ensure the electronic backpack cover is latched and taped closed, with all wires and cables tucked within the cover
- Perform an operational check of all mechanical capabilities
- Check the battery conditions (electrolyte levels, terminal connections, leaks, security, and charge)
- Perform a walk-around inspection, checking for any visible damage or disconnected harnesses
- Check the condition of all LiDAR sensory units
- Ensure the tablet is powered off and secured in the docking station for shipping

#### 3.1.2 Load the Robot

- Safely drive the robot in reverse onto the transport vehicle. Tines should be facing away from the cab of the transport vehicle.
- Place the robot within the area of installed D-ring tie-downs.
  - E-track straps may be used to secure the robot instead of chains and binders.
- Ensure the area around the robot is free of loose or unsecured items.
- Lower tines to the floor and power off the robot.
- Remove the keys and disconnect main battery power.

#### 3.1.3 Secure the Robot

- Chock wheels with wood wheel chocks, with the angled portion of the wheel chock in contact with the wheels and chassis.
  - Secure the following wheels and chassis: Front left wheel, front right wheel, steer-side chassis left of the operator cabin, steer-side chassis right of the operator cabin, left-side chassis (NOT under LiDAR fenders), and right-side chassis (NOT under LiDAR fenders)
- Secure each wheel chock with 2x T25 deck screws, angled so they make contact with the trailer floor. Do not reuse old screws.
- Securely chain or strap the mast to the floor, if possible.
- Secure the front carriage to each, D-ring, E-clip, or securing location with chain, binders, or load-rated equivalent ratchet straps.
  - Pull chain, binders, or straps in opposite directions, if possible.
  - Use 4 chains, binders, or straps at a MINIMUM (2 for the mast/side-shifter assembly and 2 inside the battery well tensioned on the chassis, NOT the battery itself).
- Install rear shipping hooks, if available, by threading into lower mounting point facing the hooks in opposite directions. Use chain and load-equivalent straps to secure to D-rings, pulling in opposite directions.



### 3.1.4 Secure the Batteries/Chargers

- Load the battery on a pallet, preferably one with battery retaining boards.
- Position the pallet near the trailer wall with available E-track spots.
- Use 2 load-rated ratchet straps to secure the long side of the battery against the trailer wall.
- If you are shipping the chargers before initial use, they will be bolted to a pallet. Ensure the cardboard cover is in place with the cabling tucked inside.
- Secure the charger with one load-rated ratchet strap against the trailer wall, in the same fashion as the batteries.



#### **WARNING**

**ALWAYS** transport the FoxBot with the “forks” facing the rear of the trailer, away from the truck cab. This is to prevent forks from being thrust into the truck cab in the event of an accident! Failure to observe this label could result in serious bodily injury or DEATH!

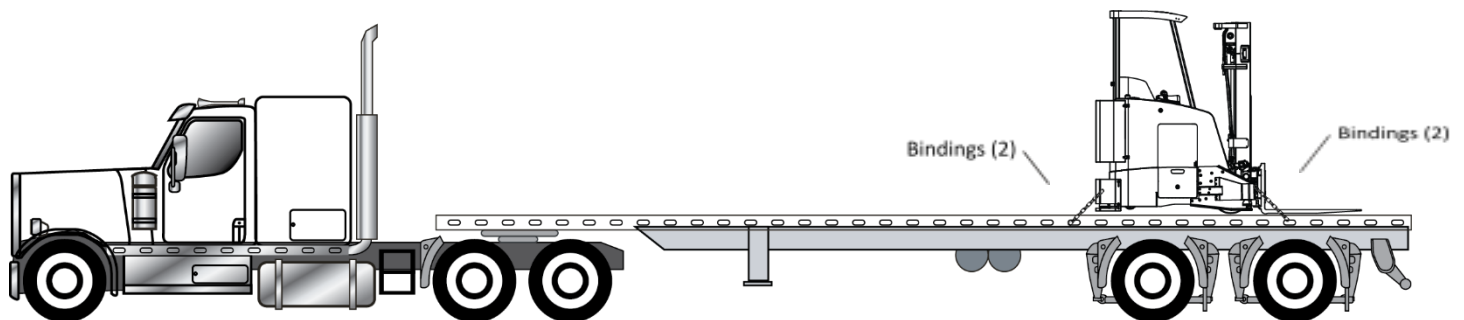

Figure 5 – Shipping a Single FoxBot

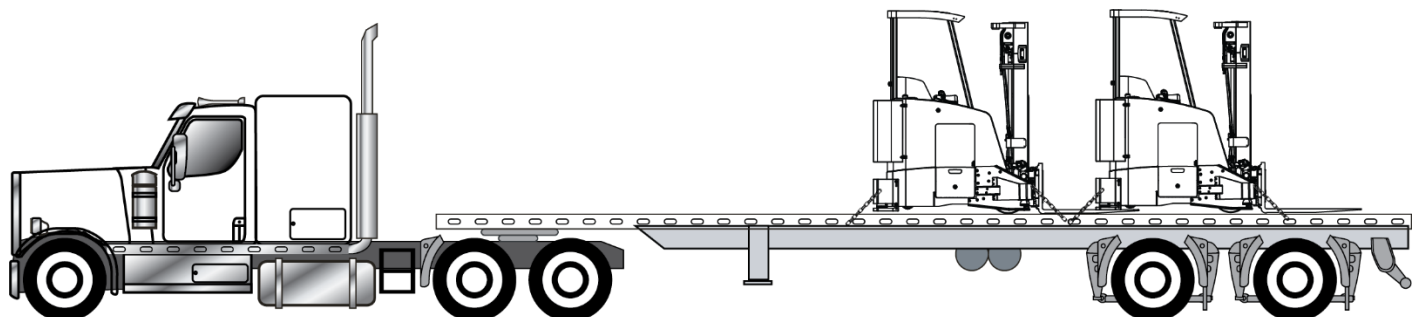

Figure 6 – Shipping Multiple FoxBots



### 3.2 Receiving and Inspections

- Remove all shipping/packaging material and verify that there are no signs of “in-transit” damage.
- Ensure that all “shipping only” brackets/braces are removed, as required.
- Ensure that all unit fasteners are tight and did not vibrate loose during transportation.



#### NOTICE

If damage is discovered, take plenty of pictures to adequately document the damage.

### 3.3 Required Site-Service Connections



#### ⚠ WARNING

Electric Forklift Charging Stations can be extremely dangerous. Ensure that only qualified, well-trained operators connect and disconnect the charging station cables. Failure to observe this label could result in serious bodily injury or DEATH!



#### ⚠ WARNING

The user shall maintain batteries and charging and charging systems in accordance with ANSI/NFPA 505. Battery types and charging systems supplied or specified by the vehicle manufacturer (e.g., opportunity charging) but not referenced in ANSI/NFPA 505 shall be maintained in accordance with instructions supplied by the vehicle manufacturer. Failure to observe this label could result in serious bodily injury or DEATH!



#### ⚠ WARNING

Battery types and charging systems supplied or specified by the vehicle manufacturer (e.g., opportunity charging) but not referenced in ANSI/NFPA 505 shall have safe operating and charging instructions supplied by the vehicle manufacturer. Failure to observe this label could result in serious bodily injury or DEATH!



Figure 6 – Sample Battery Charger



### 3.4 Designate an Operational Area and Setup

- Ensure that the operational area is prepared to accept this equipment.
- Ensure that the operational area provides ample room to operate.
- Ensure that the operational area is well lit, per ANSI/IES RP7.
- Ensure that the operational area is level (within a  $\pm 5\%$  grade) and free of debris, and/or unnecessary obstructions.
- Ensure that the operational area provides enough strength to support the weight of the equipment being placed upon it.
- Ensure that the FoxBot does NOT carry any hazardous loads.
- Ensure that all loads to be picked by the FoxBot fit with the confines of a standard Grocery Manufacturers Association (GMA) sized pallet (48" x 40").



#### NOTICE

The FoxBot's primary safety and navigation sensors are positioned to sense objects 10 cm above the ground. The operational area should be kept clear of obstacles that cannot be sensed at this height, such as overhanging obstacles or holes.



#### ⚠ CAUTION

Caution should be exercised with changed environments. Changes in weather, surface conditions, or applications may affect the vehicle stopping distance; speeds, loads, brake settings, and/or operation should be adjusted accordingly. Failure to observe this label could result in minor or moderate injury.



#### ⚠ WARNING

All operational areas of the FoxBot should be considered "hazardous zones" and precautions should be taken to avoid unnecessary safety risks. Failure to observe this label could result in serious bodily injury or DEATH!



#### ⚠ WARNING

It is also important to remember that the FoxBot is a robot and as such can turn "off" its "safety" systems without explanation. The safety systems may also simply become damaged. Pay close attention to the FoxBot's operation at all times. Failure to observe this label could result in serious bodily injury or DEATH!



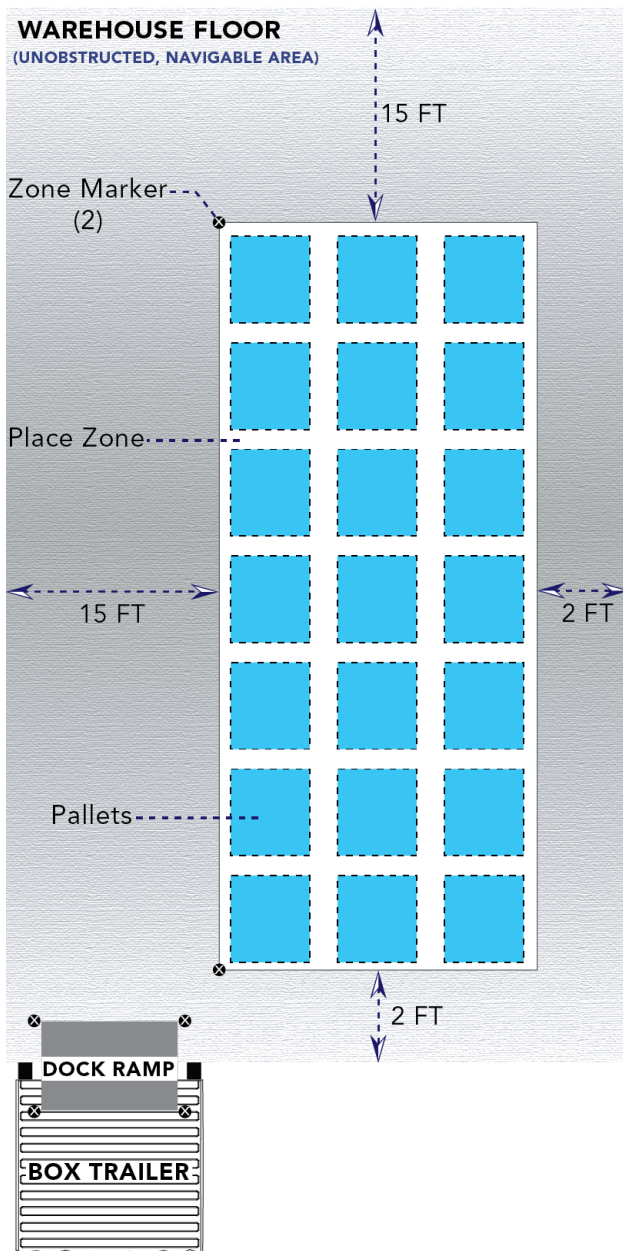

**NOTE:** A 15 ft clearance to adjacent obstacles is required for approach directions and 2 ft clearance is required for other directions.

Figure 7 – Sample Operational Area



**NOTICE**

The customer is ultimately responsible for determining a suitable operational area.





**⚠ WARNING**

The customer facility should be equipped with various signs, warning devices, and other safety devices to alert and protect personnel from contact with the vehicle or items actuated by the vehicle. This includes equipment that is designed to interact with the vehicle system. Failure to observe this label could result in serious bodily injury or DEATH!

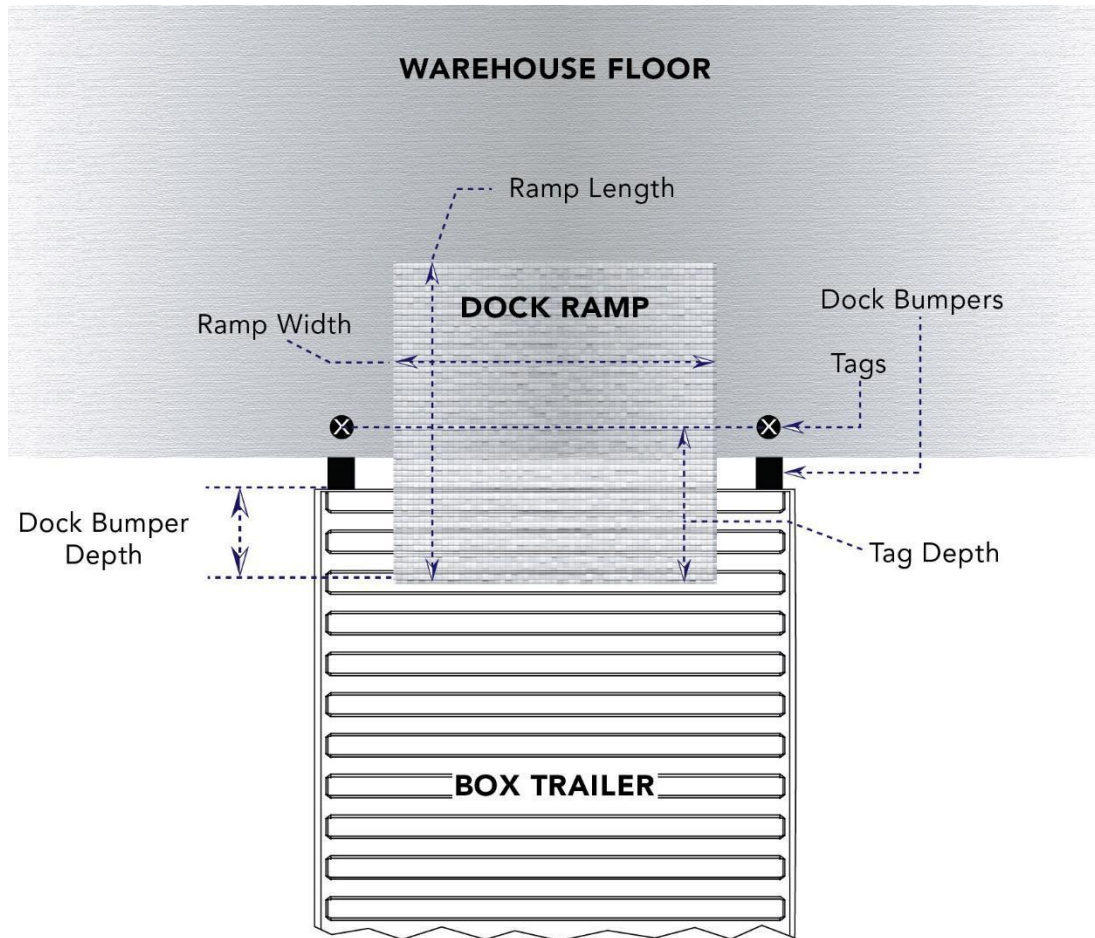

Figure 8 – Typical Dock Measurements



**NOTICE**

Record the dimensions above as they will need to be entered into the FoxLift App prior to operation.





**⚠ WARNING**

The customer is responsible for marking off a “safe travel” zone for the FoxBot. The area should be clearly marked and easily distinguishable from its surrounding area(s). Failure to observe this label could result in serious bodily injury or DEATH!

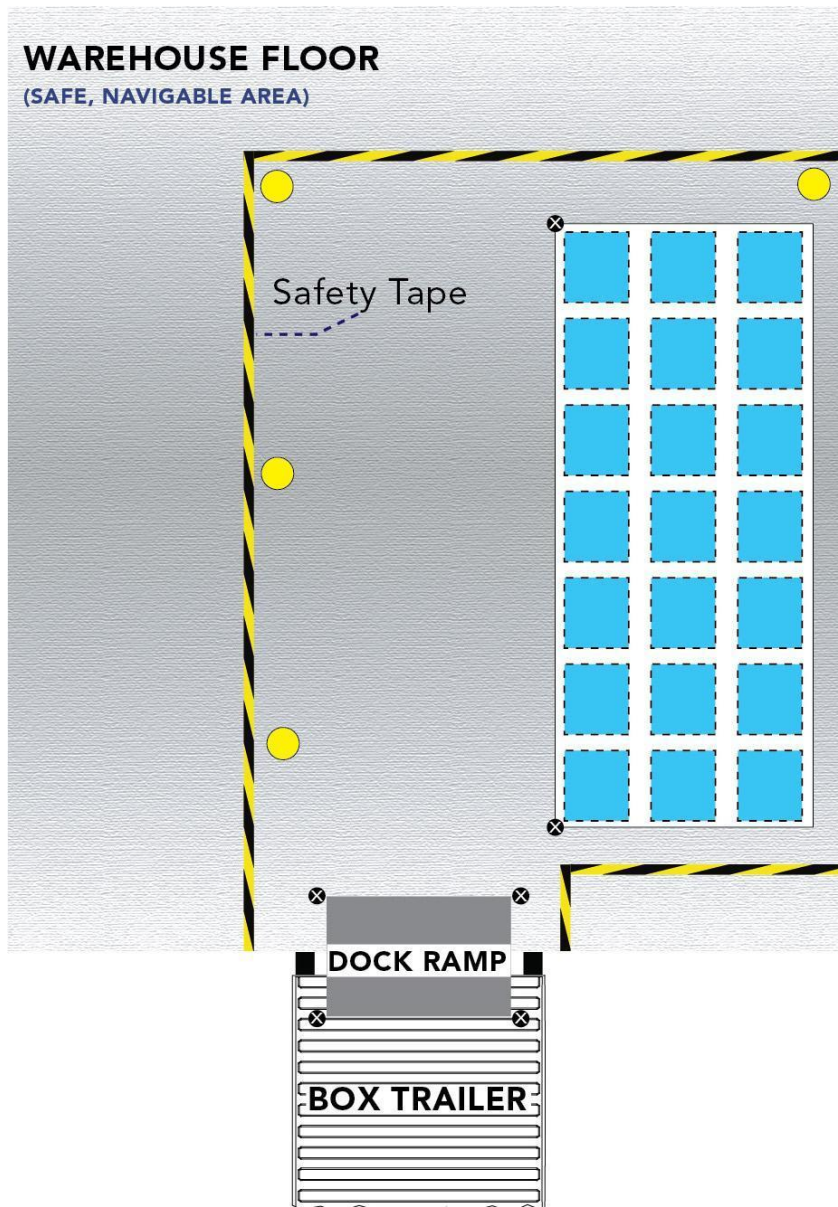

Figure 9 – Sample “Safe Travel Zone” Markings





**⚠ WARNING**

The FoxBot should always be driven at safe speeds, when operated in “Manual” mode, by a qualified operator. Failure to observe this label could result in serious bodily injury or DEATH!

### 3.5 Pre-Run Setup



**NOTICE**

The following setup instructions will only need to be done once per dock location. If multiple FoxBots will be in use at multiple dock locations, setup will have to be carried out at each location.



**NOTICE**

If the FoxBot cannot be localized (spatially) by the app (an error note within the app will indicate this), verify the condition of the sensors. They may simply need to be cleaned.

- 1) Connect all Tablets to the same WiFi network as the FoxBot. This may be a customer-provided WiFi network or the “FoxLTE” Wifi network.
- 2) Turn “ON” the onboard tablet and launch the FoxLift App.



Figure 10 – Sample Tablet (and APP)





Enter your Dock Dimensions (from section [3.4 Designate an Operational Area and Setup](#))

The screenshot shows a configuration window titled "CONFIGURE DEREK". Inside, there is a section for "Truck 3 Config" with four input fields: "Ramp Width" (1.83), "Lip to tag line" (0.82), "Ramp Length" (1.82), and "Lip to bumpers" (0.5). Below these is a checkbox labeled "Dock ramp has side walls". Underneath is a dropdown menu for "Place Zone 5 Config". At the bottom of the window are three buttons: "CANCEL", "APPLY TO THIS RUN", and "APPLY PERMANENTLY".

Figure 11 – Setup Step 1

- 3) Select your FoxBot (by name, if applicable) and “Start Run”.
- 4) Press the “Green” Button (on the Computer Enclosure) to “Home” the FoxBot.
- 5) Point the FoxBot at the “Right” Dock Tag. A “tag” is a small pole mounted sign consisting of a QR code placard sitting atop a small 4-foot pole.



**STOP**

If, at any time, the operator or nearby personnel feel there is something wrong or an unsafe condition exists, any of the 5 E-Stops may be depressed (activated) to immediately stop all FoxBot function(s).



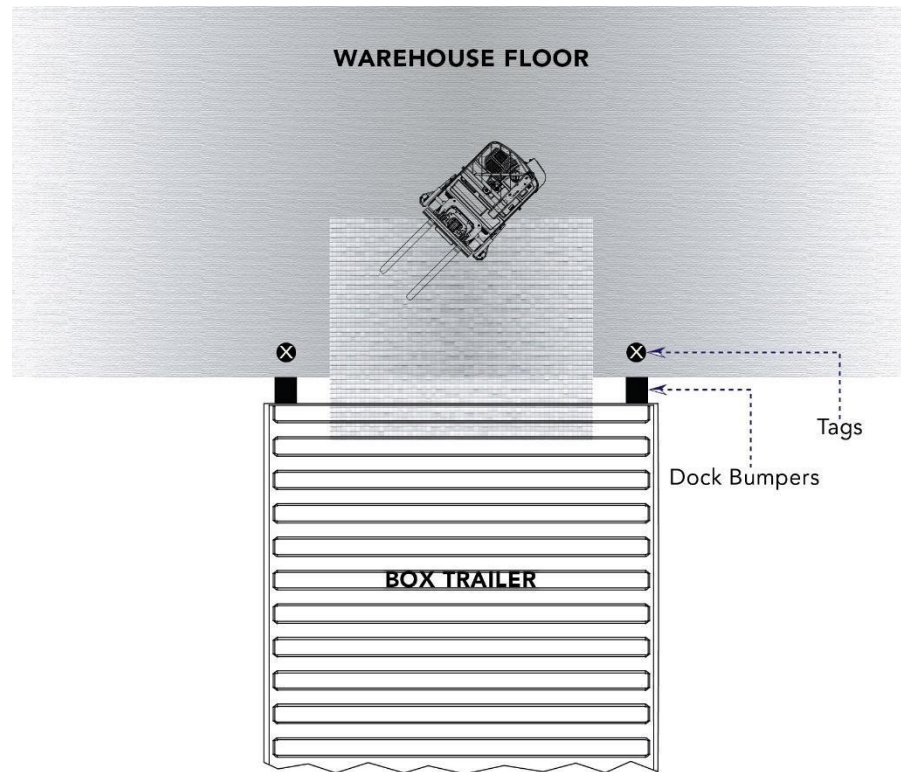

Figure 12 – Setup Step 1



**NOTICE**

Once the FoxBot finds the “tag,” it will appear as a gray box on the tablet (app) UI.



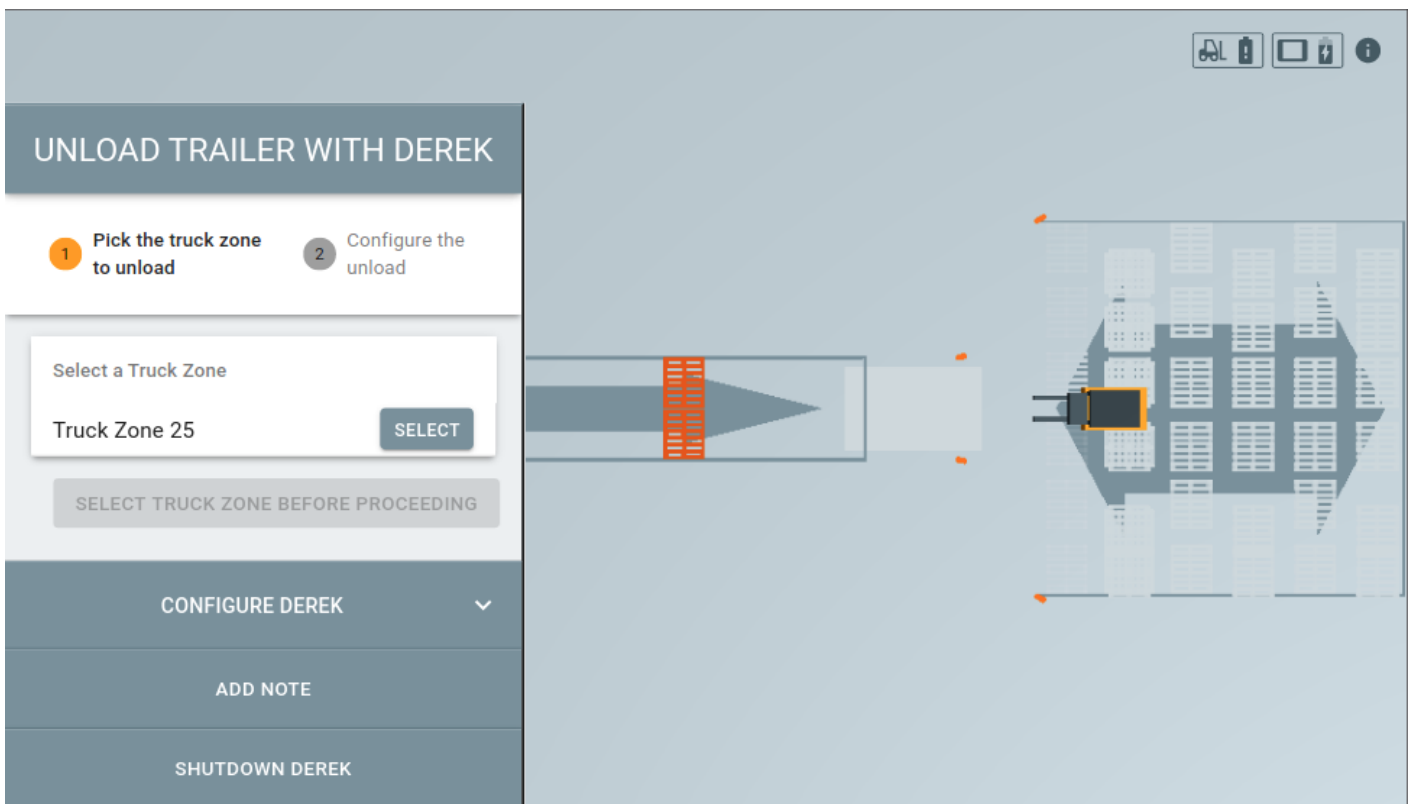
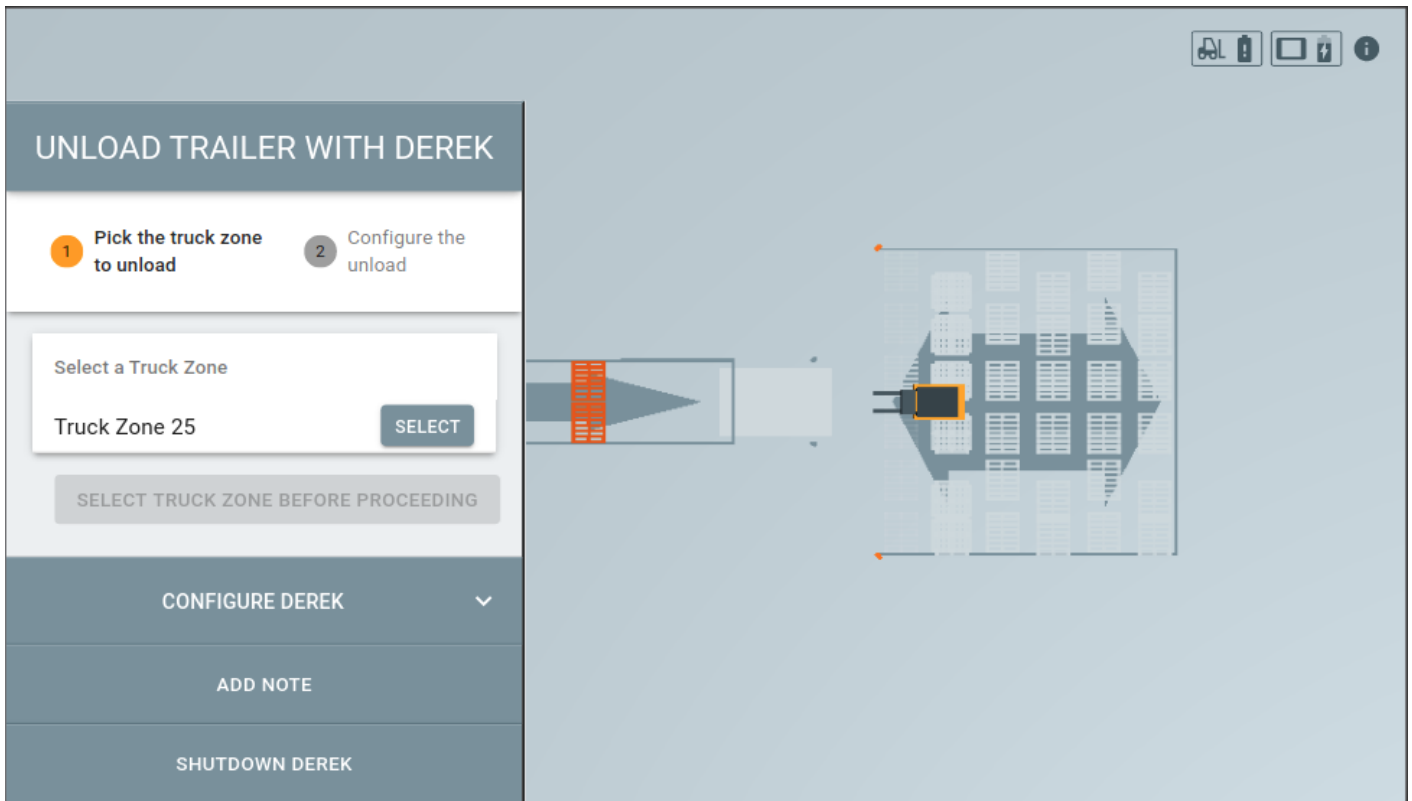

- 6) Point the FoxBot at the "Left" Dock Tag.

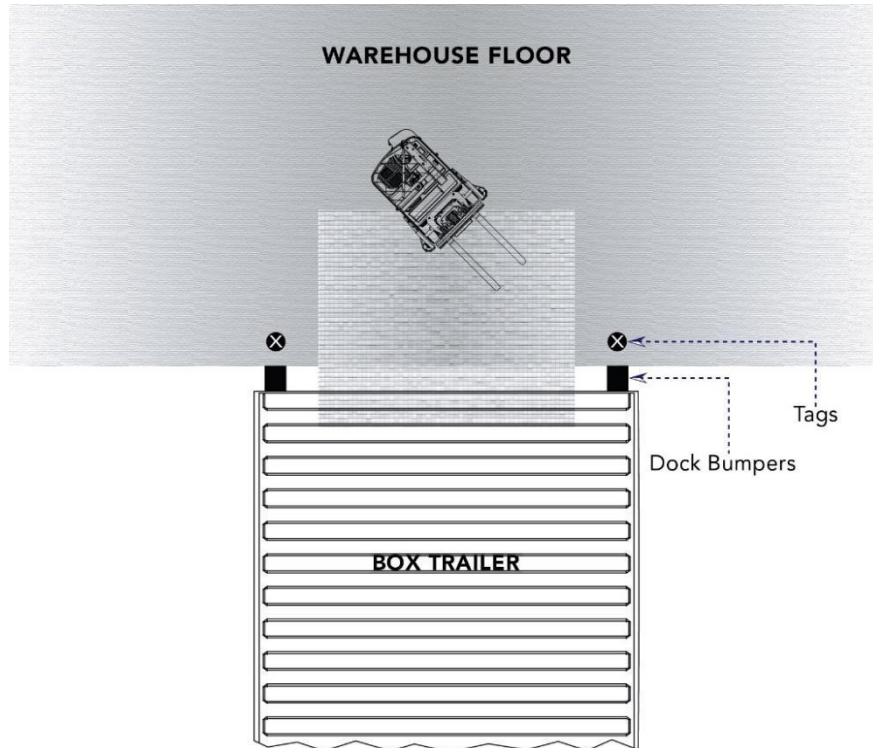

Figure 13 – Setup Step 2

- 7) Slowly drive the FoxBot inside the trailer until the camera recognizes a pallet.



**⚠ WARNING**

Inside the Truck Trailer is a hazardous area and should never be entered without first securing the FoxBot. NEVER allow the FoxBot to block easy egress from the trailer. Failure to observe this label could result in serious bodily injury or DEATH!



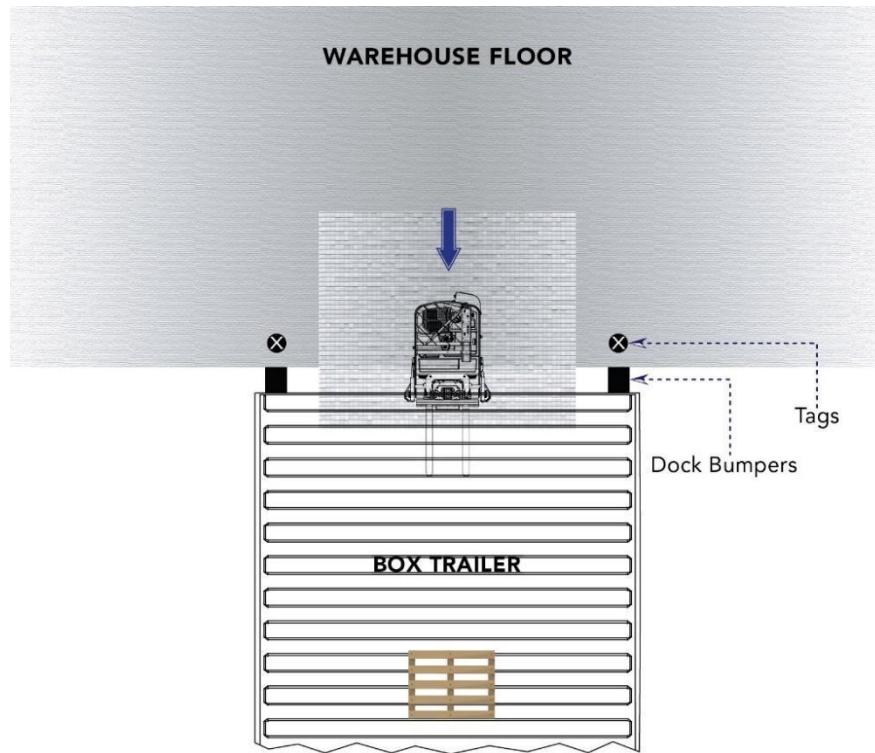

Figure 14 – Setup Step 3



## 4 Pre-operational Inspections and Testing



### NOTICE

Visual inspections should occur at the beginning of each shift and/or as issues arise during use. If any of these instructions are unclear, call Fox Robotics Engineering for resolution.



### WARNING

Prior to inspection(s) ensure that the FoxBot is resting in a safe, powered-down state. Failure to observe this label could result in serious bodily injury or DEATH!

### 4.1 Visual Inspection(s)



### STOP

Prior to operating the FoxBot, the “Daily Inspections” need to be performed. Refer to the Daily Inspection Log in the Appendix ([8.2 Inspection, Tests & Maintenance Logs](#)). If necessary, Refer to sections ([2.5 Unit Components](#) or [7 Drawings and Bills of Materials](#)) for locations of inspection items.

### 4.2 Function Tests



### STOP

Prior to operating the FoxBot, the “Daily Function Test” needs to be performed. Refer to the Daily Function Test Log in the Appendix ([8.2 Inspection, Tests & Maintenance Logs](#)). If necessary, Refer to sections ([2.5 Unit Components](#) or [7 Drawings and Bills of Materials](#)) for locations of inspection items.



## 5 Operation



### STOP

If, at any time, the operator or nearby personnel feel there is something wrong or an unsafe condition exists, any of the 5 E-Stops may be depressed (activated) to immediately stop all FoxBot function(s).



### WARNING

Fox Robotics Inc. has made every attempt to make this equipment as safe as possible. To keep this equipment operating safely, never remove (or modify) safety guards or safety labels or bypass any system put in place by Fox Robotics Inc. Failure to observe this label could result in serious bodily injury or death.



### WARNING

Only trained and authorized persons shall operate this equipment. Failure to observe this label could result in serious bodily injury or death.



### WARNING

Never use this equipment in any manner for which it was not designed. Improper use can severely impact user safety. Failure to observe this label could result in serious injury or death.



### WARNING

Any unauthorized modifications made to the components in this system can dramatically affect the overall performance of the system. Failure to observe this label could result in serious bodily injury or death.



### WARNING

Ensure that all the following procedures have been thoroughly read and understood before continuing. Failure to observe this label could result in serious bodily injury or death.



### CAUTION

Caution should be exercised with changed environments. Changes in weather, surface conditions, or applications may affect the vehicle stopping distance; speeds, loads, brake settings, and/or operation should be adjusted accordingly. Failure to observe this label could result in minor or moderate injury.





***NOTICE***

Following these instructions will minimize the risk of damaging this equipment or associated system(s).



***NOTICE***

Allowing untrained persons to operate this equipment may result in damage to this equipment and/or associated system(s).





### 5.1 Stack Light Descriptions



Figure 15 - Typical Stack Light Color Codes





### NOTICE

- 1) During normal operations, one or more Stack Light(s) should always be on or blinking. During system power-on or in the presence of a severe fault, the Stack Light may not illuminate.
- 2) A red light indicates that the FoxBot will not resume without human intervention. Even when the fault conditions are clear, the FoxBot must go through a startup procedure, indicated by a yellow blinking light (which indicates a hazard), for a period of time before resuming movement in "Autonomous" mode.



### ⚠ WARNING

**NEVER** approach a FoxBot while it is in autonomous operation unless a red light is showing. If you must approach a FoxBot while it is in autonomous operation use a tablet to cancel the current operation. Failure to observe this label could result in serious bodily injury or DEATH!

## 5.2 UPS and Battery System

### 5.2.1 Theory of Operation

To facilitate keeping the autonomy system alive through **loss of power events**, such as a changing of the primary 36V battery, the FoxBot is equipped with an Uninterruptible Power Supply (UPS) that protects the primary autonomy computer.

This UPS can select between two energy sources:

- 1) The primary forklift battery, as described in [Section 2.1 \(Performance Data\)](#). This battery provides power for the entire forklift during normal operation(s).
- 2) A secondary, 24V backup battery.

The UPS continuously monitors its own input power channel and, if it detects loss of power, will switch to the battery backup. The input power channel of the UPS is sourced from one of two locations:

- 1) If the 110V plug on the backpack is plugged in and active, then the robot is said to have **shore power**. The robot will use this channel to power the UPS. Otherwise,
- 2) The primary 36V battery is used if no **shore power** is present.

The battery backup can keep the autonomy computer alive for approximately 45 minutes on a full charge. When the backup is engaged, the system will beep slowly. Connecting the primary battery or shore power will silence this.

### 5.2.2 To Isolate Power

- 1) Remove the 110V plug into the backpack to remove shore power.

Disconnect the primary 36V battery.

Press and hold the UPS/Reset Button on the dash for 5 seconds. An audible beep should sound and the light on the switch will extinguish.



**⚠ WARNING**

Power from the backup battery into the UPS remains present even if the UPS is disabled. Complete isolation requires removal of the backup battery. Failure to observe this label could result in serious injury or DEATH!

**5.2.3 To Restore Power**

- 1) Press and hold the UPS/Reset Button on the dash for 5 seconds. An audible beep should sound and the light on the switch will illuminate.
- 2) Reconnect the primary 36V battery.
- 3) Ensure the backpack is closed and secured.

**5.3 Safe Operation Parameters**

- 1) Do **NOT** approach the FoxBot unless the stack light is red (or solid green).
- 2) Do **NOT** approach the FoxBot when the stack light is blinking or there is an audible “beeping”.
- 3) Do **NOT** enter the trailer while the FoxBot is active.
- 4) If you must approach a FoxBot while it is in autonomous operation, use a tablet to cancel the current operation.
- 5) If the vehicle is stuck, follow instructions on the tablet screen or if in doubt pick and place the next pallet manually.

**5.4 FoxBot Start-Up**

- 1) Ensure the FoxBot is disconnected from shore power.
- 1) Connect the primary 36V battery to the FoxBot (via Anderson, “Main Power” Plug).
- 2) Ensure the UPS is ON by inspecting the light switch on the dash..
- 3) Wait for the stack light to illuminate. This indicates that the system is booted up.
- 4) When the FoxBot first starts, it will automatically fault to prevent unintended motion. Press the reset button to clear it.
- 5) The FoxBot is ready to run in either manual or autonomous mode.

**5.5 Manual Mode**

Refer to the Appendix ([8.4 OEM Forklift Operation and Maintenance Manual](#)) for specific instructions on how to operate this FoxBot in manual (rider) mode.

**STOP**

If, at any time, the operator or nearby personnel feel there is something wrong with the FoxBot or an unsafe condition exists, any of the 5 E-Stops may be depressed (activated) to immediately stop all FoxBot function(s).



**⚠ WARNING**

The FoxBot should be always driven at safe speeds by a qualified operator when used in “Manual” mode. Failure to observe this label could result in serious bodily injury or death.

**⚠ WARNING**

The FoxBot is designed to carry loads that measure 40 x 48 inches or 1 x 1.2 meters, in either orientation. It is the operator's responsibility to ensure that loads do not exceed this size. A tolerance of 6 inches or 15 cm in each direction is permissible to account for loads that do not exactly conform to the pallet. The stability of the load is the operator's responsibility.

**⚠ WARNING**

If the unit stops and requires troubleshooting or any other type of human intervention, the FoxBot must be in an open space, outside of the trailer, when attempting restart procedures. This ensures both the safety of the operator and nearby personnel and proper functionality of the unit. If the unit cannot be restarted outside of the trailer, refer to section [5.7 Rescue \(Tow\) Procedures](#) for more guidance. Failure to observe this label could result in serious bodily injury or death.

## 5.6 Autonomous Mode - FoxLift App

**⚠ WARNING**

If the unit stops and requires troubleshooting or any other type of human intervention, the FoxBot shall be in an open space, outside of the trailer, when attempting restart procedures. This both ensures safety of operator and nearby personnel, and proper functionality of the unit. If the unit cannot be restarted outside of the trailer, then refer to section [5.7 Rescue \(Tow\) Procedures](#) for more guidance. Failure to observe this label could result in serious bodily injury or DEATH!

**NOTICE**

Ensure that the pre-operational warehouse and dock location setup steps have been completed prior to continuing with the App setup.

**NOTICE**

Each FoxBot delivered comes with two (2) Control Tablets. One is mounted locally on the FoxBot while the other is for remote monitoring. While the two tablets are very similar, they are not identical. The Tablet mounted on the FoxBot can only monitor and control the FoxBot that it's mounted to. The Remote Tablet can be used to setup and monitor multiple FoxBots.

- 1) Launch the FoxLift App from your local tablet.





Figure 16 – Sample Tablet (and APP)

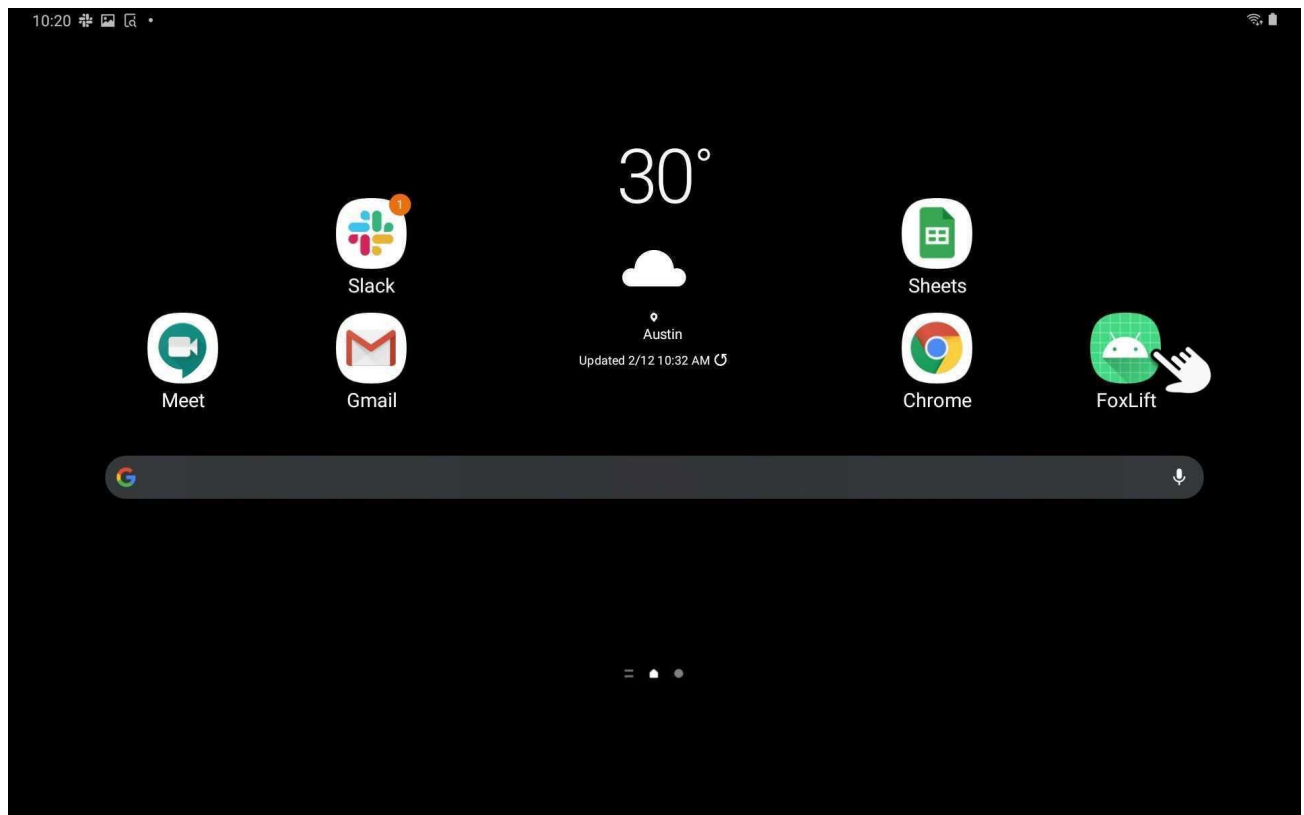

Figure 17 – Generic Tablet Home Screen (FoxLift App)



2) Select the FoxBot being set up for use.

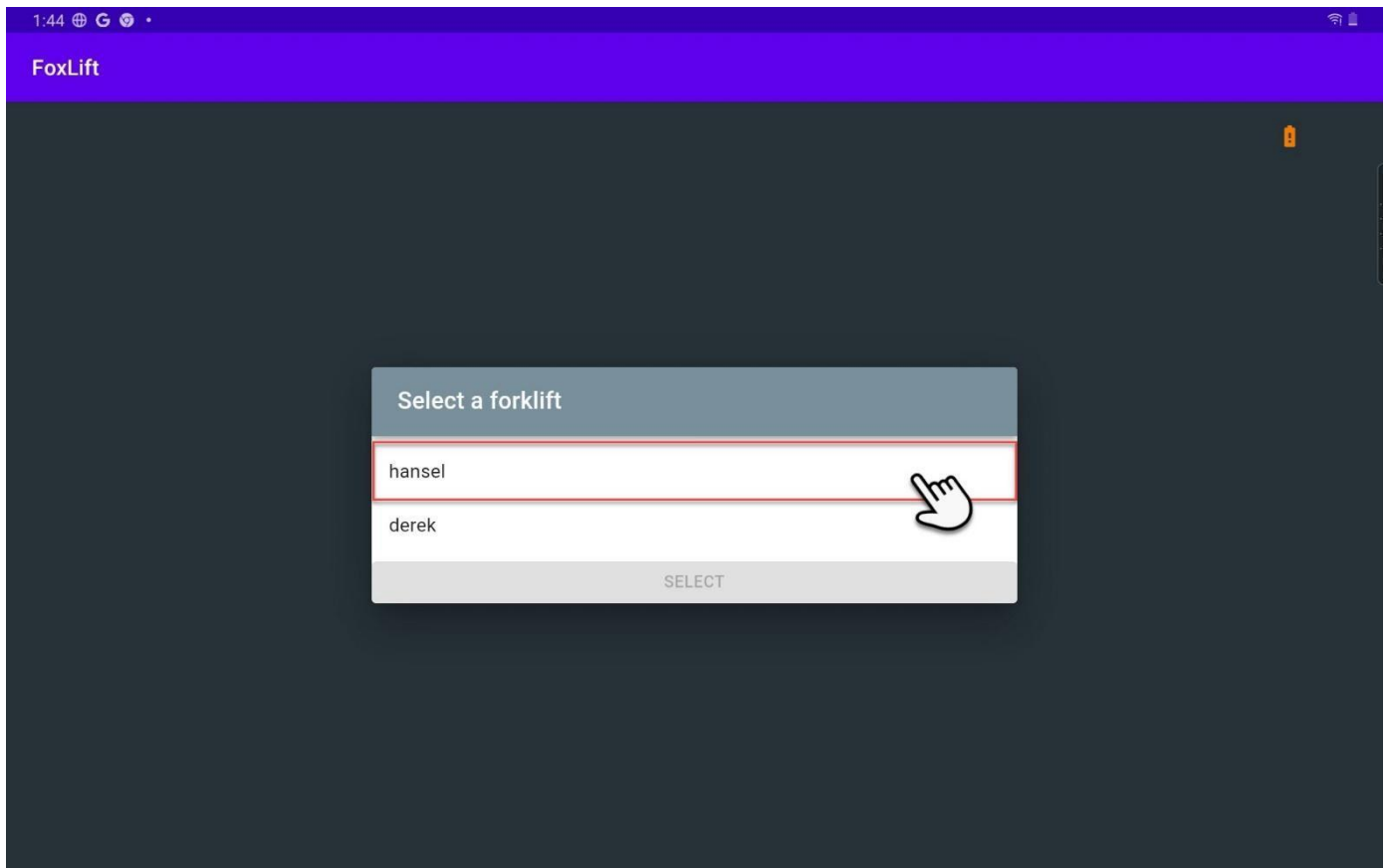

Figure 18 – Forklift Selection Screen



**NOTICE**

The names shown above are simply for illustration purposes. Your FoxBot name(s) will be different.



3) Click "START (INSERT NAME)"

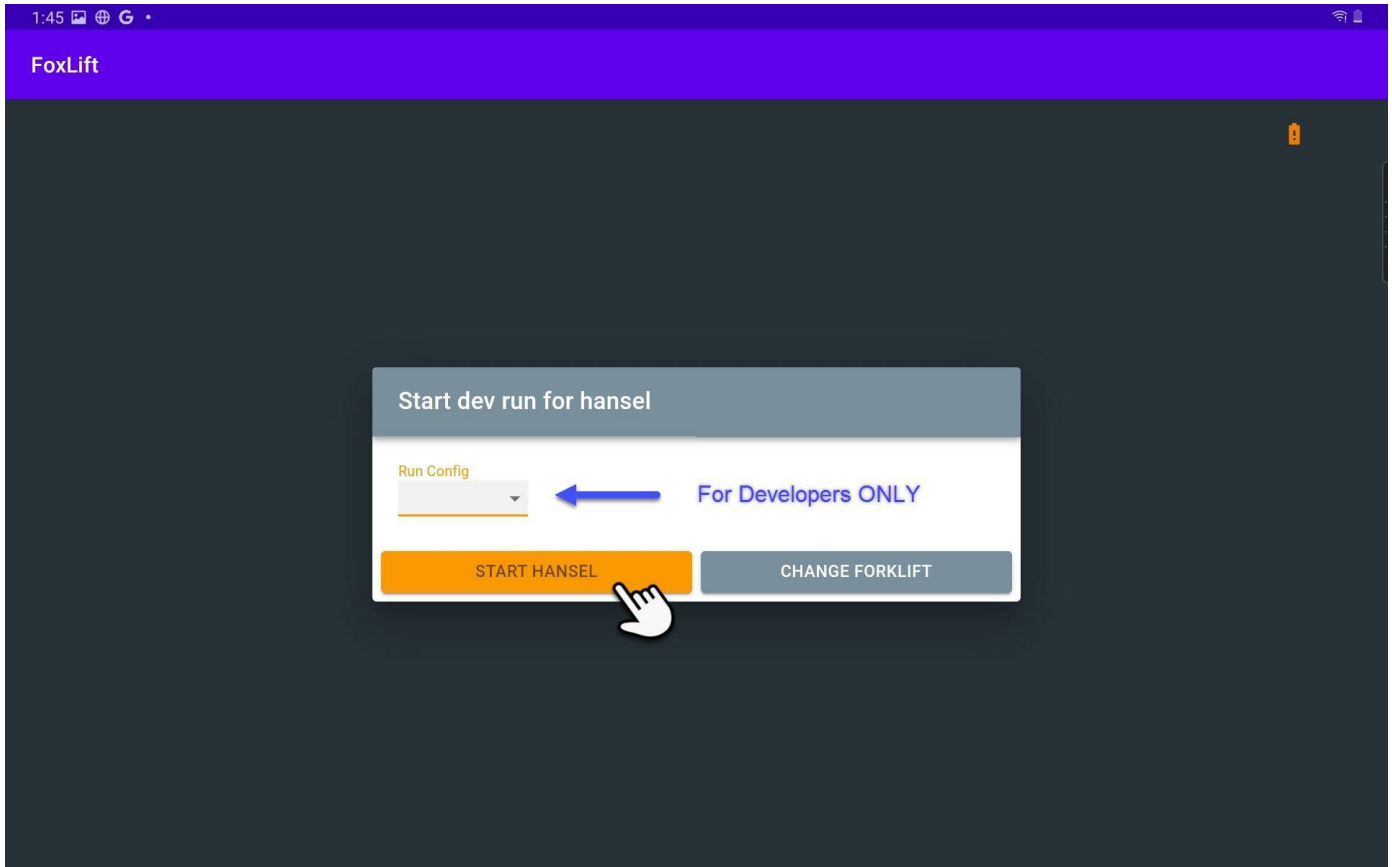

Figure 19 – Start Forklift Screen



**NOTICE**

The "Run Config" dropdown is for developers ONLY and should NOT be adjusted or modified.



4) Click "PLACE ZONE".

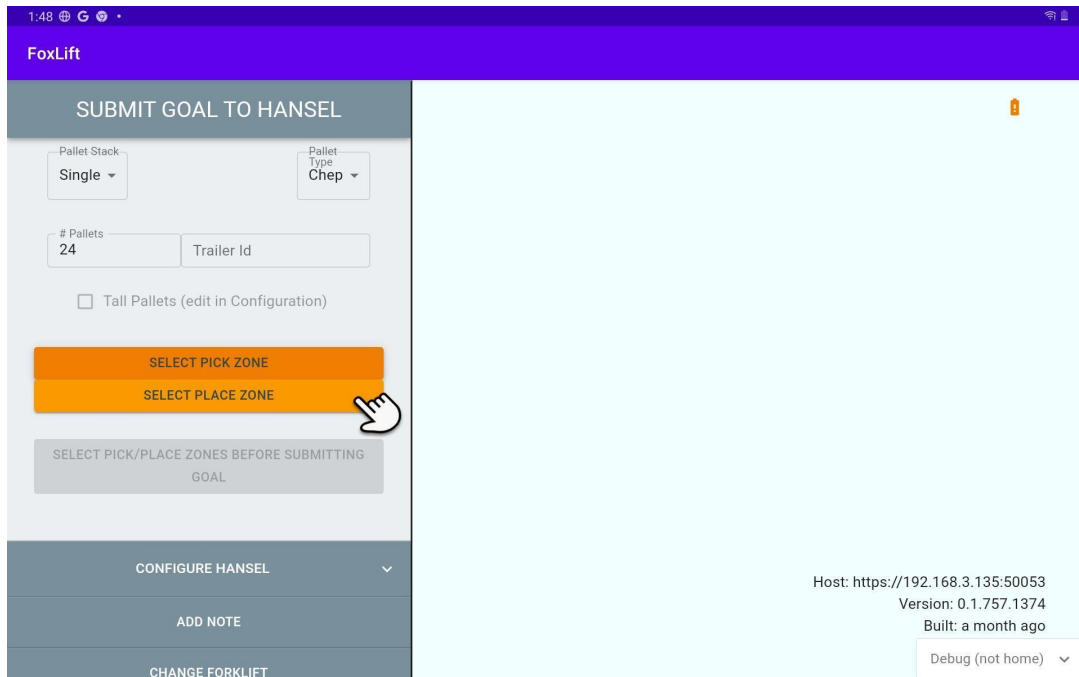

Figure 20 – Select Place Zone Screen

5) Click "PICK ZONE".

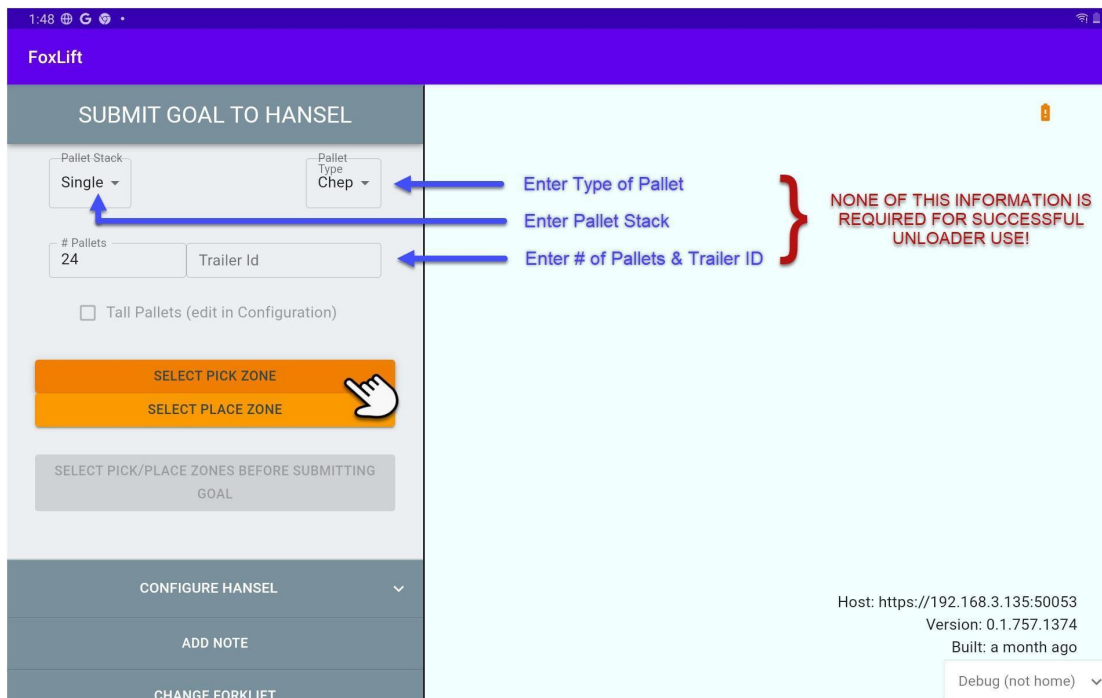

Figure 21 – Select Pick Zone Screen





6) Click "SUBMIT GOAL".

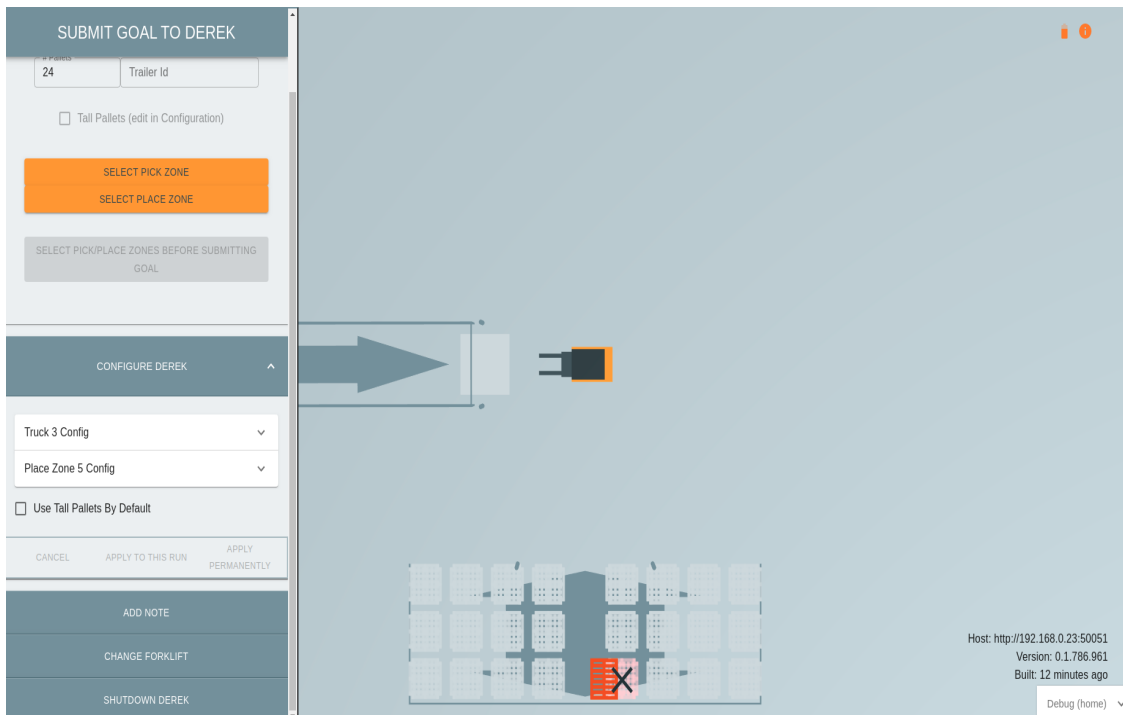

Figure 22 – Submit Goal (Run)



**NOTICE**

When the FoxBot has completed its “run”, it will simply stop where it dropped the last pallet and remain in a stopped state until either moved manually by an operator or a new goal is submitted.

**5.7 Shutdown Procedures**

- 1) From the Tablet, select "SHUTDOWN".
- 2) From the Computer Enclosure, turn the selector switch to the “Manual” mode.
- 3) From the Computer Enclosure, press the “Reset” button.
- 4) Manually drive the FoxBot to the designated “charging” station/location.
- 5) Lower the forks to the floor.
- 6) Turn off FoxBot using the key switch (turn the key CCW).
- 7) Plug in 110v shore power (if present) for the computer.
- 8) Charge the FoxBot Battery per the OEM charger instructions.
- 9) Charge the e-stop, tablet, and any other accessories.



Rescue (Tow) Procedures

If the FoxBot loses power and/or communications while inside a box trailer, it may become necessary to initiate “Rescue Tow” procedures. Use caution when executing a rescue towing procedure. When possible, minimize the distance that the FoxBot is towed, to reduce wear on tires and brakes.

Attach one end of an appropriately rated tow strap to the designated connection point on the FoxBot.

- 10) Attach the other end of the tow strap to a vehicle, capable of “pulling/towing” the FoxBot.
- 11) Carefully pull the FoxBot to the desired location.



**NOTICE**  
The brakes on the FoxBot automatically engage.

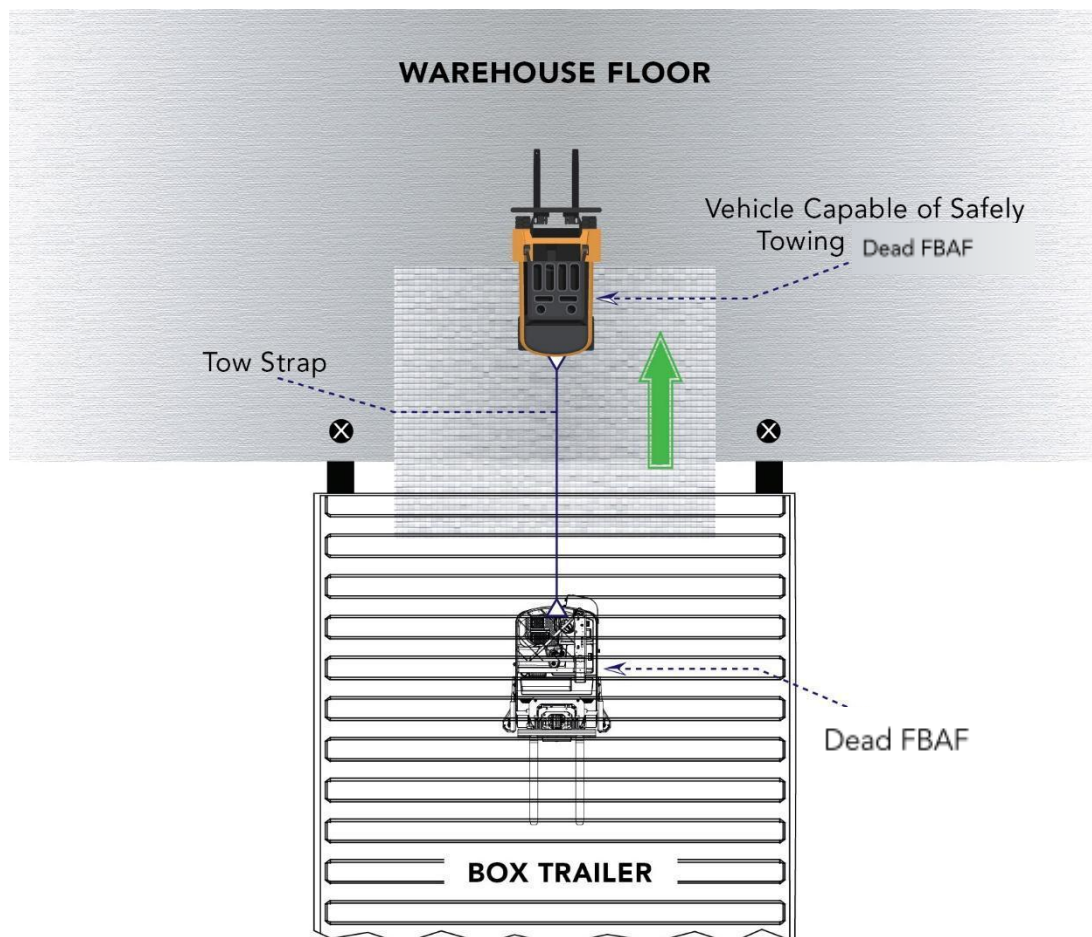

Figure 23 – Typical Rescue Tow Set-up



## 5.8 Long-Term Deactivation

It may be necessary to remove this equipment from service for extended periods of time. It is highly recommended to perform some basic preservation tasks to maximize the storage life of the equipment and minimize the expense of re-activating the equipment after prolonged storage. Aside from specific requirements, regular visual inspections should occur to ensure that the unit is protected from the harsh elements during storage.

Prior to storage, this unit should be washed with water and mild detergent and dried. This unit should be stored in a climate controlled, dry environment.

### 5.8.1 Outside Storage (exposed to the elements)

This unit is NOT rated for outside storage.

### 5.8.2 Inside Storage (protected from the elements)

All load(s) must be removed from the forks and the forks lowered to rest on the ground during long-term storage. Disconnect the main 36V battery by unplugging. (Press and hold the UPS/Reset Button on the dash for 5 seconds. An audible beep should sound and the light on the switch will extinguish.)

## 5.9 Reactivation



### **WARNING**

**Do not use worn or outdated parts. When in doubt, contact Fox Robotics Inc. for the appropriate replacement part. Failure to observe this label could result in serious bodily injury or DEATH!**



### **NOTICE**

**Additionally, using worn or outdated parts may result in damage to this equipment and/or associated system(s)!**

All assemblies (partial or fully assembled) require a full and detailed inspection prior to re-activation. Some equipment may require only minor adjustments while others may need to be completely refurbished with new seals and/or other perishable parts depending on the length of time the equipment was in storage and how well the periodic inspections/maintenance was carried out.

Key items to inspect include all rubber products, seals of any kind and all equipment components with moving parts.



## 6 Maintenance



### **WARNING**

Prior to performing any maintenance activities, of any kind, confirm that all energized or pressurized circuits are off and/or bled to zero. Failure to observe this label could result in serious injury or DEATH!



### **WARNING**

Maintenance should be performed by well qualified technicians, who are familiar with all operational aspects of this equipment. Failure to observe this label could result in serious injury or DEATH!

This section provides general guidelines for the maintenance of the Fox Robotics, FoxBot Autonomous Forklift (FoxBot). For maintenance activities that fall outside the scope of this manual, refer to the Appendix ([8.4 OEM Forklift Operation and Maintenance Manual](#)) for specific maintenance instructions on the basic model “forklift”.



### **WARNING**

Any component modification and/or configuration change to the components in this system, without approval from Fox Robotics, can dramatically affect the overall performance of the system. Failure to observe this label could result in serious bodily injury or DEATH!



### **WARNING**

In the event that the system supplier is no longer in business and there is no successor to the business, the user may arrange for a modification or alteration to this FoxBot provided the user:

- (a) arranges for modification or alteration to be designed, tested, and implemented by an engineer(s) expert in Automatic Guided Industrial Vehicles and their safety,
- (b) maintains a permanent record of the design test(s), and implementation of the modification or alteration,
- (c) makes appropriate changes to the capacity plate(s), decals, tags, and operation and maintenance manuals.
- (d) affixes a permanent and readily visible label on the truck stating the manner in which the truck has been modified or altered together with the date of the modification or alteration, and the name of the organization that accomplished the tasks.

Failure to observe this label could result in serious bodily injury or DEATH!



## 6.1 Lock Out, Tag Out Procedure



### ⚠ WARNING

Follow your site’s Lock Out, Tag Out (LOTO) procedures to ensure that this equipment is put into a “safe” state. If no procedure(s) exist, then follow the below instruction. Failure to observe this label may result in death or serious injury.

- 1) From the FoxBot operator cabin (area), turn the key to the “OFF” position.
- 2) Disconnect the Anderson (main power) Plug from the battery.
- 3) If present, install a LOTO lock on the main battery connector cover. Otherwise, install an Anderson plug lockout device to prevent inadvertent power-up.
- 4) Attach a “Out of Service” tag (or similar) in a highly visible location. Such as steering wheel or key.
- 5) Once Maintenance activities are complete, remove all lock out devices and tags.
- 6) Reconnect the Battery’s Anderson Plug back to the battery.
- 7) From the FoxBot’s operator cabin (area), turn the key to the “ON” position, to operate or test as desired.

## 6.2 Preventative Maintenance (PM) Schedule (General)



### NOTICE

To satisfy all warranty conditions, the customer is responsible for carrying out all recommended preventative maintenance below unless otherwise noted in a Supplier Agreement or Purchase Order.

#### Maintenance Task

##### Daily

All regular maintenance recommended by the OEM. See Appendix, ([8.4 OEM Forklift Operation and Maintenance Manual](#)) for guidance.

See section ([8.2 Inspection, Tests & Maintenance Logs](#)).

##### Weekly

All regular maintenance recommended by the OEM. See Appendix, ([8.4 OEM Forklift Operation and Maintenance Manual](#)) for guidance.

See section ([8.2 Inspection, Tests & Maintenance Logs](#)).

##### Monthly, Quarterly, 6 Month, and Annually

All regular maintenance recommended by the OEM. See the Appendix, (All regular maintenance recommended by the OEM. See Appendix, ([8.4 OEM Forklift Operation and Maintenance Manual](#)) for guidance.) for guidance.

*\*The time intervals presented are only suggested maintenance levels and are not necessarily the only time inspection or maintenance may be necessary for safe operation. If abnormal conditions arise, stop and inspect / repair immediately.*





**NOTICE**

Function Testing should be carried out after any repairs, adjustments, or component replacements to this equipment, to ensure satisfactory FoxBot operation.



**WARNING**

Prior to re-energizing/activating this unit, ensure that all associate maintenance personnel have removed their Lock Out Device, as per your site’s LOTO program. Failure to observe this label could result in serious injury or DEATH!

Maintenance and Support Services (Optional Service)

Additionally, Fox Robotics will provide the following Preventative Maintenance Services (subject to the conditions and payments specified in a Supplier Agreement or Purchase Order).



**NOTICE**

Fox Robotics will **NOT** provide “daily, weekly, or monthly” PM services. The customer is solely responsible for performing the “daily, weekly, and/or monthly” PM tasks.

**Maintenance Task**

**Quarterly**

All regular maintenance recommended by the OEM. See the Appendix, (All regular maintenance recommended by the OEM. See Appendix, ([8.4 OEM Forklift Operation and Maintenance Manual](#)) for guidance.) for guidance.

Visually inspect all Automation Equipment and Vehicle Components.

Calibrate and Maintain all onboard components, in accordance with the OEM’s recommended service intervals

**6 Month**

All regular maintenance recommended by the OEM. See the Appendix, (All regular maintenance recommended by the OEM. See Appendix, ([8.4 OEM Forklift Operation and Maintenance Manual](#)) for guidance.) for guidance.

Lubricate the Mast Rollers, Lift Brackets, Lift Chain, Tilt Socket, Tilt Cylinder, and Main Drive Gear.

**Annually**

All regular maintenance recommended by the OEM. See the Appendix, (All regular maintenance recommended by the OEM. See Appendix, ([8.4 OEM Forklift Operation and Maintenance Manual](#)) for guidance.) for guidance.

Replace the Drive Axle Oil, Hydraulic Tank Oil Filter, and Hydraulic Oil.





**NOTICE**

Fox Robotics will carry out functional testing on the FoxBot and offboard equipment to verify that any component repairs or revisions made during the inspection service satisfy acceptable standards for operational performance, as determined by Fox Robotics.



**NOTICE**

Fox Robotics will provide maintenance and testing of the following components:  
 Drive Components, Safety Lasers, Optical Lenses, Position Sensors, Hydraulic Attachments, Operator Interface, and all Offboard Equipment, as required by the FoxBot application (FoxLift App).

### 6.3 Troubleshooting



**NOTICE**

For general “forklift” troubleshooting, refer to the Appendix, [8.4 OEM Forklift Operation and Maintenance Manual](#) for guidance.



**⚠ WARNING**

If the unit stops and requires troubleshooting or any other type of human intervention, the FoxBot shall be in an open space, outside of the trailer, when attempting restart procedures. This both ensures safety of operator and nearby personnel, and proper functionality of the unit. If the unit cannot be restarted outside of the trailer, then refer to section [5.7 Rescue \(Tow\) Procedures](#) for more guidance. Failure to observe this label could result in serious bodily injury or DEATH!

#### 6.3.1 FoxBot Autonomous Forklift

Symptom	Possible Cause	Remedy
FoxBot loses its path (clear path) during Autonomous operation	Obstruction in the way	Remove obstruction
	Dirty/damaged LiDAR Sensor	Clean/replace Sensor
FoxBot won't move	Active E-Stop	Find active E-Stop and deactivate
	Weak battery	Charge/replace battery
	Loose/bad battery connection/cable	Replace/repair cable/connector



FoxBot no power	Dead battery	Replace battery
	Loose/bad battery connection/cable	Replace/repair cable/connector

**6.3.2 Charging Station/Unit**

Symptom	Possible Cause	Remedy





## 6.4 Maintenance Procedures



### **WARNING**

Prior to performing maintenance of any kind, ensure that this equipment is isolated from its power source and “Tagged” and “Locked” OUT of SERVICE to prevent inadvertent operation. Refer to your company’s Lock Out, Tag Out (LOTO) Procedure, for guidance. Failure to observe this label could result in serious bodily injury or DEATH!



### **WARNING**

Prior to performing maintenance of any kind, ensure that the “Parking Brake” is applied to prevent the unit from moving. Failure to observe this label could result in serious bodily injury or DEATH!

## 6.5 General Precautions

- Unless being actively worked on, keep all electrical enclosures properly closed and labeled.
- Before servicing electrical equipment, ensure that power is OFF by means of a voltmeter or other approved indicator.
- Be aware that there may be more than one means of power isolation to electrical components.
- If the FoxBot needs to be raised to perform maintenance, then ensure that it is sufficiently blocked/choked to prevent it from unexpectedly falling/rocking/ tipping, etc.

### 6.5.1 Battery Charging



### **DANGER**

Charging lead acid batteries is a hazardous activity and extreme care must be used when dealing with charging batteries. Failure to observe this label will result in death or serious injury.



### **WARNING**

Battery types and charging systems supplied or specified by the vehicle manufacturer (e.g., opportunity charging) but not referenced in ANSI/NFPA 70 shall have safe operating and charging instructions supplied by the vehicle manufacturer. Failure to observe this label could result in serious bodily injury or DEATH!

### 6.5.2 Parking Brake

Aside from the daily inspections, the Parking Brake should be tested regularly for functionality. It should be capable of holding back the entire weight of the unit (unloaded), independently of the primary braking systems and with the power source removed.



### 6.6 Post Maintenance Results

- Perform a thorough, visual inspection of the unit for signs of leaks/abnormalities/damage resulting from maintenance.
- All test equipment calibration certificates should be kept with these test results for future reference, if applicable.
- All post-maintenance test results should be kept with this manual for future reference.

Comments: \_\_\_\_\_  
 \_\_\_\_\_  
 \_\_\_\_\_  
 \_\_\_\_\_

### 6.7 Results and Witness Sign-offs

**Equipment Identification**

Date of Maint:    /    /	Maint. Performed By:
Serial Number:	Equip Description:

Procedure Step #	Pass or Fail	Maintenance Supervisor	Remarks
	P / F		
	P / F		
	P / F		
	P / F		
	P / F		

**Additional Information**

_____ <b>Maintenance Performed By (Signature):</b>	_____ / ____ / ____ <b>Date of Maintenance</b>
-------------------------------------------------------	---------------------------------------------------

**MAINTENANCE WITNESSED AND ACCEPTED BY**

Organization	Witness	Signature



## 7 Drawings and Bills of Materials

Drawings, schematics, and diagrams provide a general view of overall equipment layout, components, location, dimensions, and other useful information required for installation, operation, and maintenance activities.



### NOTICE

All information provided on these drawings is "As Built". Any changes or field modifications that may have taken place, WILL NOT be reflected on these drawings.

### 7.1 Drawing List

DRAWING NUMBER	DESCRIPTION	PAGE



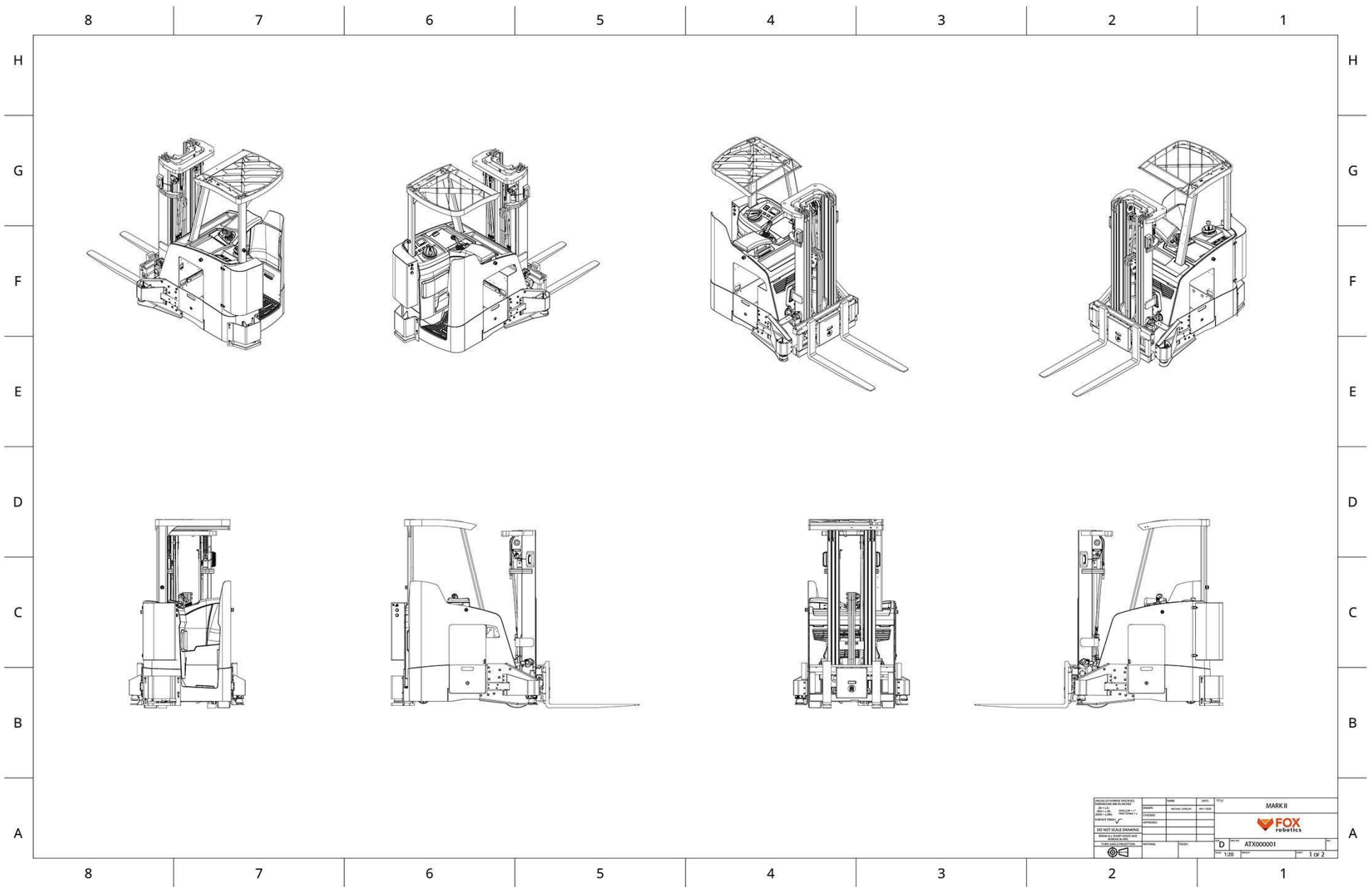

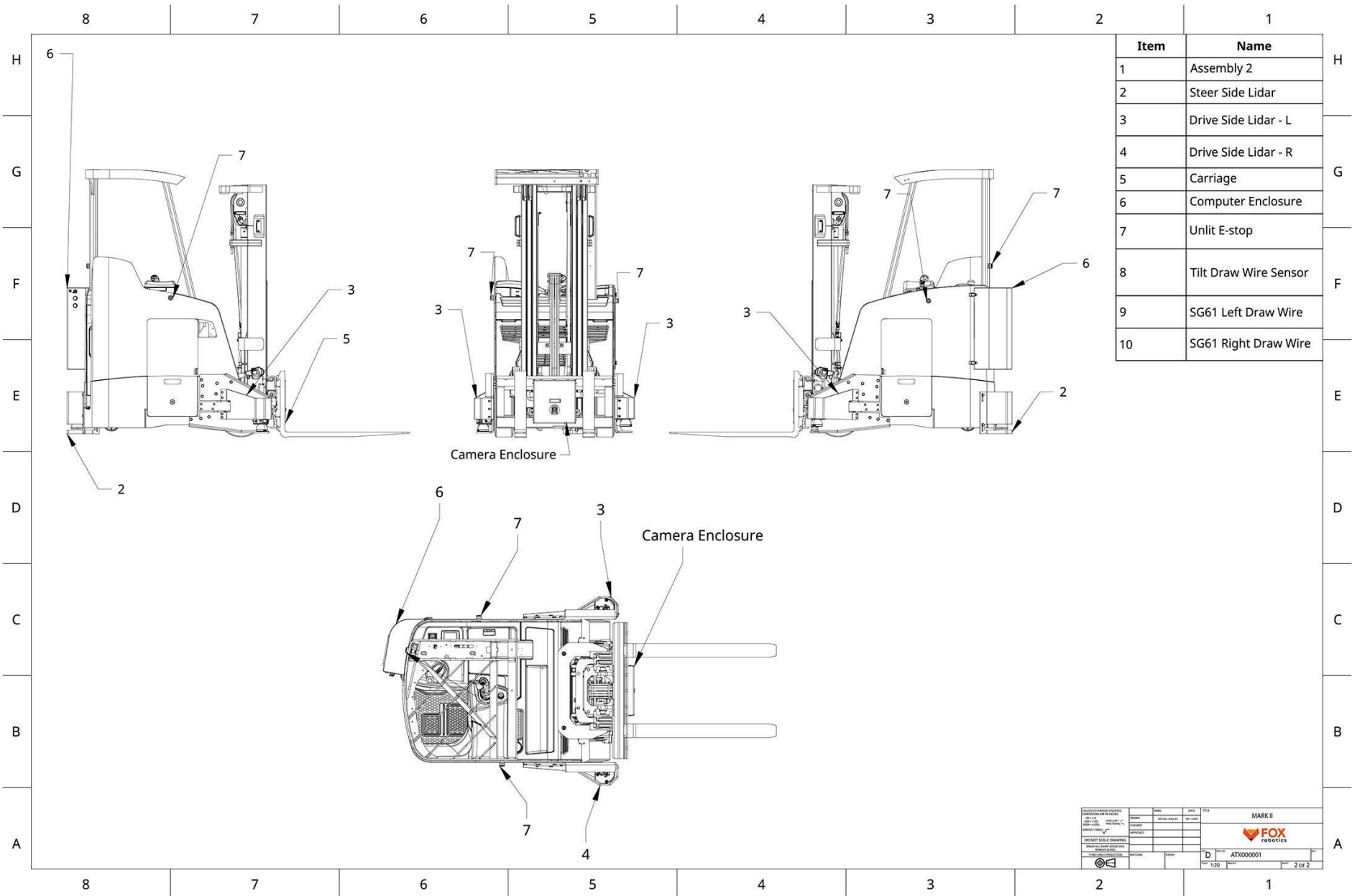

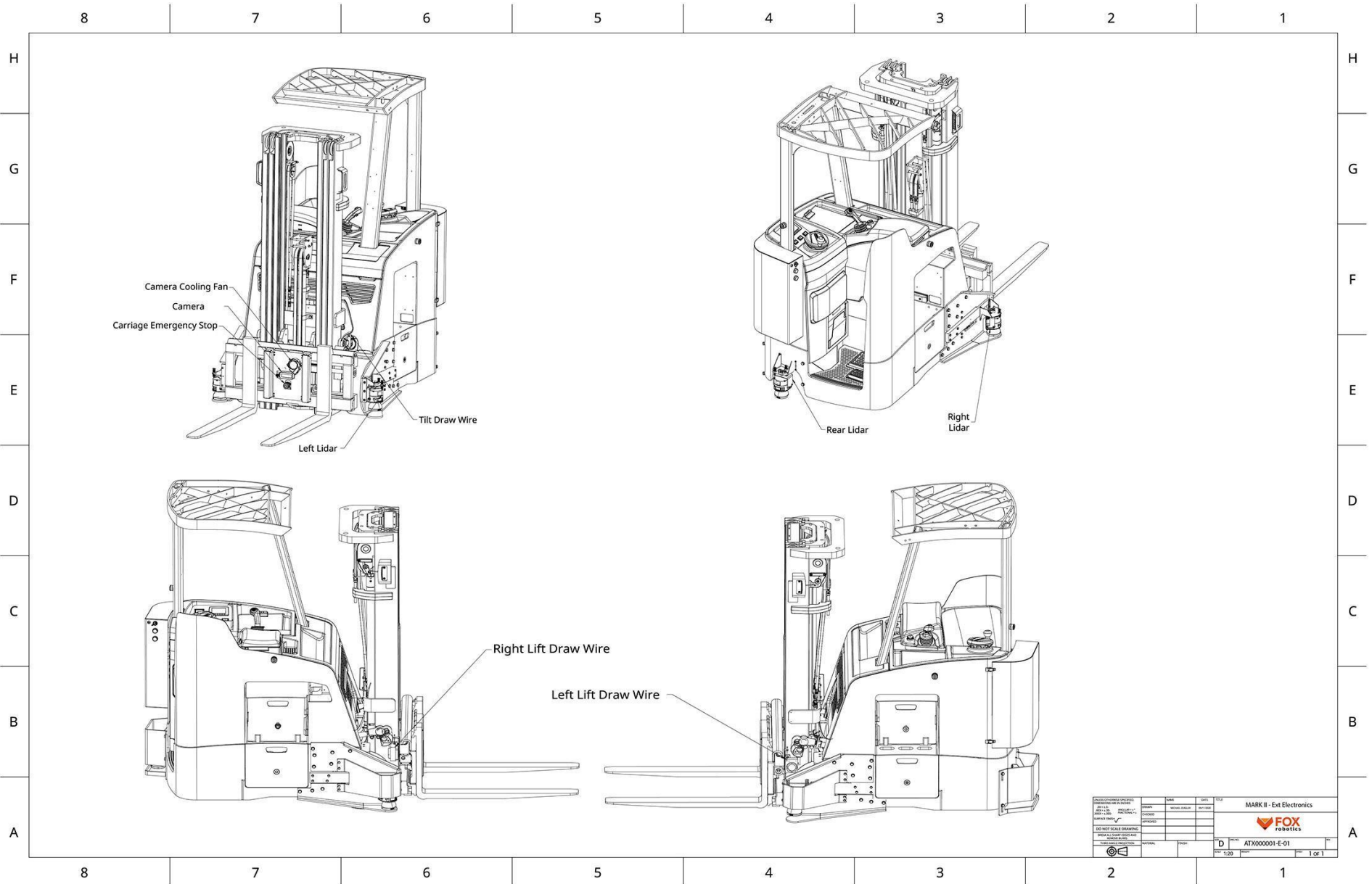

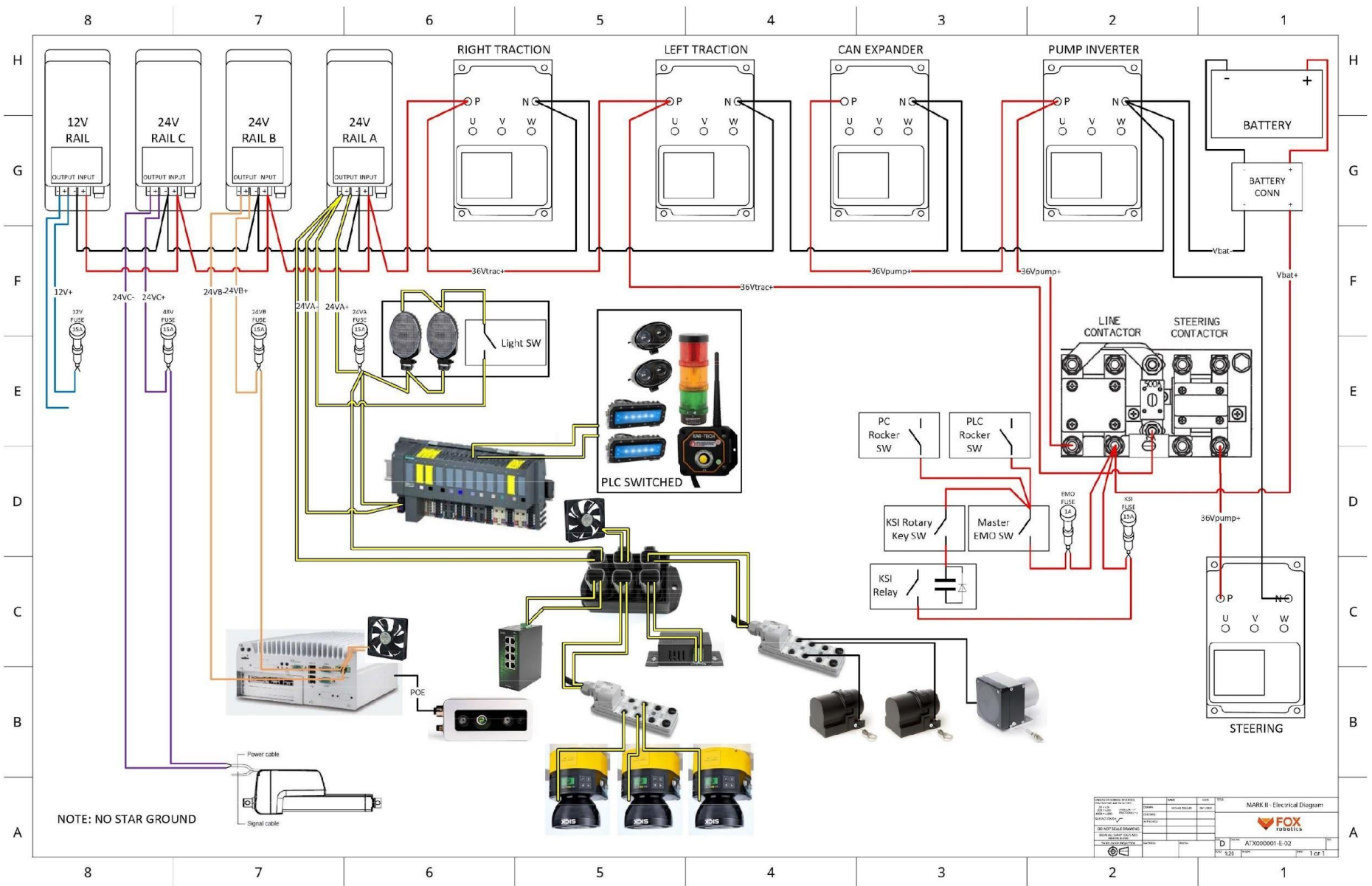



## 8 Appendix

### 8.1 Terms and Abbreviations

A	_____	Amps
ANSI	_____	American National Standards Institute
ASME	_____	American Society of Mechanical Engineers
ATT	_____	Attachment
CW	_____	Clockwise
CCW	_____	Counter-Clockwise
ESD	_____	Emergency Shut-Down
E-Stop	_____	Emergency Stop
GUI	_____	Graphic User Interface
in	_____	Inches
LF	_____	Left-Handed
mA	_____	Milliampere
mm	_____	Millimeter
OEM	_____	Original Equipment Manufacturer
OPS	_____	Operator Presence Sensor
OSHA	_____	Occupational Safety Health Administration
PPE	_____	Personal Protective Equipment
PS	_____	Power Steering
QMS	_____	Quality Management System
RH	_____	Right-Handed
STD	_____	Standard
UI	_____	User Interface
VAC	_____	Volts of Alternating Current
VDC	_____	Volts Direct Current
WLL	_____	Working Load Limit



## 8.2 Inspection, Tests & Maintenance Logs



### ***NOTICE***

Copies of the Daily and Weekly logs shall be provided as stand-alone documents. Completed logs should be completed and stored where other maintenance records are kept.

### 8.2.1 Daily Inspections

- [FOX-ENG-SOP-001 - Daily Inspections](#)

### 8.2.2 Daily Function Tests

- [FOX-ENG-SOP-002 - Daily Function Tests](#)

### 8.2.3 Weekly Inspections

- [FOX-ENG-SOP-003 - Weekly Inspections](#)



### 8.3 OEM Forklift Specifications | FBCS14N

DESIGNED TO PERFORM IN VERY CONFINED SPACES.

# FBCS14N-FBCS18N

3,000 - 4,000 LB CAPACITY  
STAND-UP COUNTERBALANCED FORKLIFT

## 1. Flexible

### Maneuverable Design

The stand-up counterbalance's space-saving design allows the truck to stack and retrieve goods efficiently in significantly narrower aisles than other counterbalanced trucks and at high lift heights, allowing you to maximize space.

### Personalized Solutions

Designed with standard cushion tires and a variety of mast and load handling options, the FBCS14N-FBCS18N series is ideal for dock-to-stock applications, shuttling goods or moving large loads in confined spaces.

## 2. Smart

### AC Control System

The PM-1000 Alternating Current (AC) hydraulic system provides competitive lift speeds with precise fork movement, resulting in increased productivity for your application.

### Performance Customization

Three programmed performance modes and a number of performance parameters can be adjusted from the display to suit a wide range of operator and application requirements or preferences.

## 3. Efficient

### In Control

The intuitive, multi-function control handle is centrally positioned for easy access to truck functions and offers simultaneous control of drive, lift/lower and auxiliary hydraulic functions.

### Electric Power Steering

Electric power steering provides improved energy efficiency, operator comfort and serviceability over traditional hydrostatic power steering.

## 4. Ergonomic

### Enhanced Comfort

The stand-up counterbalance features a suspended anti-fatigue floor board that can adjust to the operator's weight. The adjustable armrest and backrest fit around the operator, providing comfort during the entire shift.

### 4" HD full color display

The easy-to-read control panel displays the information the operator needs to perform daily tasks, such as load weight, travel speed, 360° steer direction, event message indicator and more.



CHARACTERISTICS			FBCS14N	
1	Capacity at rated load center	lb kg	3,000	1,364
2	Capacity load center - distance from fork face	in mm	24	600
3	Power voltage	V	36 AC electric	
4	Tire type, drive / steer		solid rubber / poly	
5	Wheels (x=driven)		2x / 2	
DIMENSIONS				
6	Maximum fork height lift with standard triplex mast	in mm	188	4,775
7	Free fork height lift with standard triplex mast	in mm	35	889
8	Fork width	in mm	3.9	100
9	Fork thickness	in mm	1.4	35
10	Fork spacing – out-to-out minimum	in mm	9.5	240
11	Fork spacing – out-to-out maximum	in mm	36.5	920
12	Tilt angle, forward / backward	deg	3 / 5	
13	Mast width	in mm	22	570
14	Length to fork face	in mm	63.0	1,601
15	Overall chassis width	in mm	41	1,041
16	Overall lowered height (mast)	in mm	82.9	2,105
17	Overall lowered height to top of overhead guard	in mm	88.0	2,240
18	Overall height with extended mast	in mm	236.6	6,009
19	Step height	in mm	9.4	240
20	Battery roller height	in mm	7.0	178
21	Load moment constant <sup>[2]</sup>	in mm	12.2	310
22	Minimum outside turning radius <sup>[3]</sup>	in mm	50.8	1,291
23	Minimum aisle – 90° stack – zero clearance <sup>[1]</sup> (turning radius + load moment constant + load length + aisle clearance)			
PERFORMANCE				
24	Travel speed, loaded / empty	mph kph	8 / 8	12.9 / 12.9
25	Lift speed, loaded (triplex)	mph kph	83	0.42
26	Lift speed, empty (triplex)	fpm m/s	118	0.60
27	Lower speed, loaded (triplex)	fpm m/s	102	0.52
28	Lower speed, empty (triplex)	fpm m/s	98	0.50
29	Gradeability, loaded (maximum) at 1 mph / 1.6 km/h	%	15	
30	Gradeability, empty (maximum) at 1 mph / 1.6 km/h	%	15	
WEIGHT				
31	Truck weight – empty with minimum weight battery	lb kg	8,424	3,829
32	Battery weight (minimum)	lb kg	1,700	773
33	Battery weight (maximum)	lb kg	2,000	909
CHASSIS				
34	Chassis type, stand / sit		stand	
35	Wheelbase <sup>[4]</sup>	in mm	41.7	1,059
36	Ground clearance – center of wheelbase	in mm	4.0	102
37	Ground clearance – lowest point at mast	in mm	3.0	76
38	Tire size, drive	in	16 x 7 x 10.5	
39	Tire size, steer	in	10 x 5 x 6.5	
40	Brake type		electromagnetic disc	
ELECTRICAL				
41	Traction motor type		AC induction	
42	Traction motor output kW (60 minute rating)	HP kW	5.4 (x2)	4.0 (x2)
43	Pump motor type		AC induction	
44	Pump motor output kW (15% rating)	HP kW	17.4	13.0
45	Steer motor type		AC induction	
46	Steer motor output kW (60 minute rating)	HP kW	0.9	0.7
47	Battery maximum capacity – A/H (6 hour rating)	AH	1,240	
48	Battery compartment length (front - back)	in mm	14.25	362
49	Battery compartment width (side - side)	in mm	38.50	978
50	Battery compartment height	in mm	32.00	813

[1]Add load length and operator clearance.  
 [2]Add 2.25" (57.0 mm) for quad masts; add 2.50" (63.5 mm) for hang-on side shift / hang-on shift fork positioner options; Add 1.00" (25.4 mm) for integrated side shift only; Type E, EE (optional), Industrial Trucks. Users should be aware of, and adhere to, applicable codes and regulations regarding operator training, use, operation and maintenance of powered industrial trucks, including:  
 • ANSI/ITSDF B56.1.  
 • NFPA 505, fire safety standard for powered industrial trucks -type designations, areas of use, maintenance and operation.  
 • Occupational Safety and Health Administration (OSHA) regulations that may apply.  
 [3]Turning Radius: battery compartment 14.25" = 50.8" (1291mm); battery compartment 16.25" = 52.8" (1342mm); battery compartment 18.25" = 54.8" (1393mm); battery compartment 21.25" = 57.8" (1469mm);  
 [4]Wheelbase: battery compartment 14.25" = 41.7" (1059 mm); battery compartment 16.25" = 43.7" (1110 mm); battery compartment 18.25" = 45.7" (1161 mm); battery compartment 21.25" = 48.7" (1237 mm);

**SAFETY STANDARDS**  
 These trucks meet American National Standards Institute/Industrial Truck Standards Development Foundation, ANSI/ITSDF B56.1. UL-Classified by Underwriters Laboratories, Inc., as to fire and electric shock hazard only; Type E, EE (optional), Industrial Trucks. Users should be aware of, and adhere to, applicable codes and regulations regarding operator training, use, operation and maintenance of powered industrial trucks, including:  
 • ANSI/ITSDF B56.1.  
 • NFPA 505, fire safety standard for powered industrial trucks -type designations, areas of use, maintenance and operation.  
 • Occupational Safety and Health Administration (OSHA) regulations that may apply.  
 Specifications, equipment, technical data, photos and illustrations based on information at time of printing and subject to change without notice. Some products may be shown with optional equipment.



# FBCS14N-FBCS18N

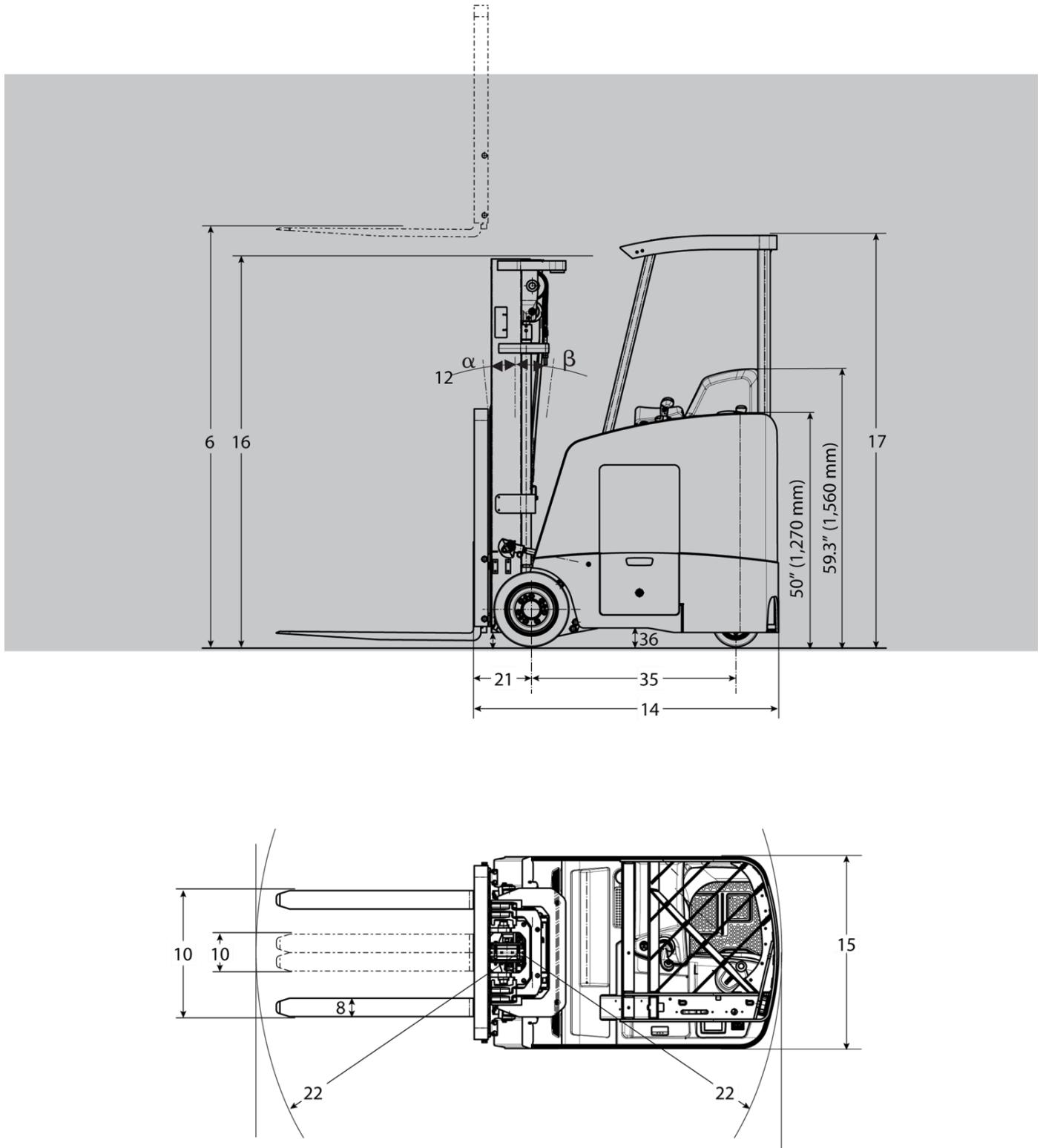

# FBCS14N-FBCS18N

3,000 - 4,000 LB CAPACITY STAND-UP COUNTERBALANCED FORKLIFT

## Flexible Operation

### 1. The One-Truck-Fits-All Solution

With optional quad masts along with various load handling options, the stand-up counterbalance series is as comfortable in a trailer as it is in the warehouse.

### 2. The Specific Solution

For applications requiring added protection from potential fire or electrical shock risks, these forklifts can be configured with an optional UL type EE rating.

### 3. Designed for Drive-in Racks

Designed with your application in mind, the FBCS14N-FBCS18N series comes standard with an overhead guard that works in drive-in-racks. A 50" backrest (lowered from the standard 60" extension) height plus the non-adjustable armrest and backrest padding are necessary for this application. This option can be used with the 83" and 91" overhead guard.

### 4. Freezer And Cooler Packages

To help keep the truck running smoothly in some of the harshest conditions, these packages include features and low-temperature fluids that can all be installed in the truck to fit the requirements of those applications.

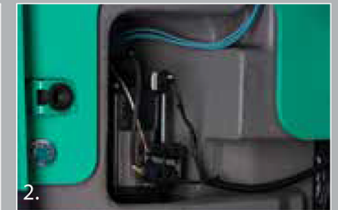

Manufactured with superior quality and exceptional value, Mitsubishi forklift trucks are supported by an extensive dealer and field support network located throughout North and South America. Don't forget to ask your local Mitsubishi forklift truck dealer about details on factory retail programs, financing plans and additional options and dealer services like planned maintenance and operator training.

Copyright © 2018. All rights reserved. All registered trademarks are the property of their respective owners.

Some products may be shown with optional equipment.

MEHM0204

10/18



## 8.4 OEM Forklift Operation and Maintenance Manual





# Operation & Maintenance Manual

## Stand-Up Counterbalance Forklift Truck

<b>FBCS14N</b>	AFB50-00011-09999
<b>FBCS16N</b>	AFB51-00011-09999
<b>FBCS18N</b>	AFB52-00011-09999





# FOREWORD

The Occupational Safety and Health Administration (OSHA) prohibits employees under the age of 18 years old from operating forklift trucks, and is now mandating operator training for all forklift truck operators.

SAFE and EFFICIENT OPERATION of a forklift truck depends to a great extent on the skill and alertness of the operator. To develop the skill, the operator should read this manual to understand the following points.

- (1) Working capabilities and limitations of the forklift truck.
- (2) Make-up of the forklift truck.
- (3) Safe driving and load handling procedures.

It is the employer's responsibility to make sure the operator can see, hear and has the physical and mental ability to operate the forklift truck safely.

It is also important that a qualified person experienced in forklift truck operation should guide new operators through several driving and load handling operations before they attempt to operate the forklift truck on their own.

**Note:**

- This manual contains information necessary for the operation and "Do-it-yourself" maintenance of standard forklift trucks.
- Optional equipment is sometimes installed; it can change some operating characteristics described in this manual. Before operating such a forklift truck, make sure the necessary instructions are available and understood.
- Forklift truck operator training is provided through your authorized dealer. They will be glad to help you and answer any questions you may have about operating your new forklift truck. Forklift trucks are NOT intended for use on public roads.
- If you resell a forklift truck, be sure to attach the original Operation & Maintenance Manual to the forklift truck. In some countries, strict regulations do not allow imported forklift trucks for resale. For resale information, contact your authorized dealer.
- If a forklift truck is resold from another country, an Operation & Maintenance Manual attached to the forklift truck may not meet your country's rules and regulations. For manual information, contact your authorized dealer.
- If your forklift truck has an attachment, refer to the attachment supplier for the proper attachment operating instructions.

## HOW TO USE THIS MANUAL

The following safety signs and NOTE are used in this manual to emphasize important and critical instructions.

 This is the safety alert symbol. It is used to alert you of potential personal injury hazards or damage that could occur to property or the environment. Obey all safety messages that follow this symbol to reduce the risk of serious injury, death, or damage.

Be sure to read these precautionary instructions and all safety related decals installed on your forklift truck before you operate it.

### DANGER

DANGER indicates a hazardous situation which, if not avoided, will result in death or serious injury.

### WARNING

WARNING indicates a hazardous situation which, if not avoided, could result in death or serious injury.

### CAUTION

CAUTION, used with the safety alert symbol, indicates a hazardous situation which, if not avoided, could result in minor or moderate injury.

**NOTE:** Note indicates important matters and useful information on operation and maintenance.

 This sign indicates prohibited matters.

We cannot anticipate every possible circumstance that might involve a potential hazard. The warnings in this publication and on the product are therefore not all inclusive.

If a tool, procedure, work method or operating technique is not specifically recommended, you must satisfy yourself that it does not pose a safety hazard to yourself and others. You should also ensure the product will not be damaged or made unsafe by the operation, lubrication, maintenance or repair procedures you choose.

All information, specifications, and illustrations in this manual are based on the latest data available at the time of publication. The specifications, torques, pressures, measurements, adjustments, illustrations, and other items can change at any time. These changes can affect the service given to the product.

Obtain the most complete and current information from your authorized dealer before starting any job. Additional manuals are available from your authorized dealer.

#### **Directional terms:**

The directions "Left", "Right", "Front" and "Rear" are given from the viewpoint of the operator facing forward.

# Forklift Truck Models Covered in This Manual

<b>Model</b>	<b>Serial Number</b>
FBCS14N	AFB50-00011-09999
FBCS16N	AFB51-00011-09999
FBCS18N	AFB52-00011-09999

## LOCKOUT/TAGOUT

LOCKOUT is not only used to disconnect a power supply, but also to physically isolate power sources from supplying power to the forklift truck, with a lockout device, disabling the forklift truck.

TAGOUT also reduces the risk of operating the machine during LOCKOUT with the use of a "DO NOT OPERATE" or similar warning tag. Warning tags are ideally placed on the lockout device to indicate the forklift truck must not be operated until the tag is removed. Combined use of LOCKOUT/TAGOUT reduces the risk of accidental or inadvertent operation.

A forklift truck that has been LOCKED OUT and TAGGED OUT must not be operated until the required service has been completed and the forklift truck is no longer LOCKED OUT and TAGGED OUT.

**NOTE:** In the United States, employers have a responsibility to provide a safe workplace under the regulations of the Occupational Safety and Health Administration (OSHA). For more information on OSHA LOCKOUT/TAGOUT see the 29 CFR 1910.147 and Appendix A to 29 CFR 1910.147 (available at [www.osha.gov](http://www.osha.gov)).

### WARNING

- Personnel could be exposed to death or serious injury if LOCKOUT/TAGOUT procedure is not performed prior to servicing the forklift truck.
- Only the trained technician who performs the LOCKOUT/TAGOUT procedure must release the forklift truck back into service.
- Only proper LOCKOUT/TAGOUT devices must be used.

### WARNING

Basic requirements before servicing equipment:

- Wear appropriate personal protective equipment.
- Move equipment to secure maintenance area.
- Park the forklift truck on a hard and level surface with the forks lowered until the forklift tips touch the ground, parking brake applied, direction lever in the NEUTRAL position, engine stopped, and the wheels blocked.
- Turn the key switch to the OFF position.
- Remove the key from the key switch.

Typical LOCKOUT/TAGOUT procedures are shown below:

#### **Battery forklift truck**

- (1) Remove the key to the forklift truck from the key switch and access the battery compartment.
- (2) Disconnect the battery plug/connector and their connections from the forklift truck and place in the proper lockout device.
- (3) Lock the lockout device.
- (4) TAGOUT the forklift truck by placing a "DO NOT OPERATE" or similar warning tag where it can be visibly seen.
- (5) After the work is finished, the technician with the key to the forklift truck must unlock the lockout device and remove the tag.

## TABLE OF CONTENTS

### CHAPTER 1 SAFETY RULES FOR FORKLIFT TRUCK OPERATORS

1.1 General.....	1 - 1
1.2 Operating Environment.....	1 - 2
1.3 Location of Warning and Safety Decals.....	1 - 2
1.4 Description of Danger, Warning, and Caution Decals.....	1 - 4
1.4.1 Load Forks and Mast Warning Decal.....	1 - 4
1.4.2 General Warning Decal.....	1 - 5
1.4.3 Alarm Must Sound Decal.....	1 - 7
1.4.4 Overhead Guard Impact Decal.....	1 - 7
1.4.5 Pinch Point Decal.....	1 - 7
1.4.6 High Voltage Danger Decal.....	1 - 7
1.4.7 Load Backrest Extension Warning Decal.....	1 - 8
1.4.8 Warning Operation Without This Device Decal.....	1 - 8
1.4.9 Multi-function Control Handle Decals.....	1 - 8
1.4.10 Fuse Label Decal.....	1 - 9
1.4.11 Lubrication Instructions Decal.....	1 - 9
1.4.12 UL Decal.....	1 - 10
1.4.13 Reinstall Manual Decal.....	1 - 10
1.4.14 Nameplate.....	1 - 10
1.4.15 Capacity Plate.....	1 - 10
1.4.16 Fuse Warning Decal.....	1 - 11
1.4.17 Capacity Decal.....	1 - 11
1.4.18 Lubrication and Maintenance Chart.....	1 - 11
1.4.19 Battery Compartment Limits.....	1 - 11
1.5 Safety Rules.....	1 - 11
1.6 Operating Precautions.....	1 - 20

### CHAPTER 2 KNOW YOUR FORKLIFT TRUCK

2.1 Controls and Indicators.....	2 - 1
2.2 Operator Display.....	2 - 9
2.2.1 Display Unit.....	2 - 9
2.2.2 Setting the Display Unit.....	2 - 10
2.2.3 Keyless Access Systems.....	2 - 15
2.2.4 General Information About Operation with Keyless Access Systems.....	2 - 15
2.2.5 Operating the Keypad.....	2 - 15
2.2.6 Operation of the Display Unit.....	2 - 19
2.3 Functionality of Operator Presence System.....	2 - 22
2.3.1 Preventing Operator's Absence.....	2 - 22
2.3.2 Mast Operation.....	2 - 22
2.3.3 Travel Operation.....	2 - 22
2.4 Controlled Roll Back Function.....	2 - 23
2.5 Battery Disconnect.....	2 - 23
2.6 Fork Pins.....	2 - 23
2.7 Replacing the Forks on a Forklift Truck.....	2 - 24
2.8 Safety Equipment.....	2 - 24
2.9 Additional Warning Devices.....	2 - 25

---

## **CHAPTER 3 HOW TO AVOID A TIPOVER / HOW TO SURVIVE ONE**

---

3.1 Know What Forklift Truck Stability Is.....	3 - 1
3.2 Do's and Don'ts to Avoid Tip Over.....	3 - 3

---

## **CHAPTER 4 OPERATION**

---

4.1 New Forklift Truck Break-In.....	4 - 1
4.2 Before Starting Operations.....	4 - 1
4.3 Before Moving the Forklift Truck .....	4 - 1
4.3.1 Before Moving the Forklift Truck - Overview.....	4 - 1
4.3.2 Start-Up Procedure.....	4 - 1
4.4 Adjustable Comfort Operator Platform.....	4 - 2
4.5 Adjusting the Arm Rest.....	4 - 3
4.6 Forklift Truck Operation.....	4 - 3
4.7 Changing Speed.....	4 - 4
4.8 Travel Direction.....	4 - 4
4.8.1 Travel Direction Definition.....	4 - 4
4.8.2 Parking Brake Warning Icon.....	4 - 5
4.9 Changing Directions.....	4 - 5
4.10 Braking.....	4 - 5
4.11 Plugging.....	4 - 8
4.12 At the End of Each Shift.....	4 - 8

---

## **CHAPTER 5 OPERATING TECHNIQUES**

---

5.1 Stacking Methods.....	5 - 1
5.1.1 Stacking Loads Differing in Size.....	5 - 1
5.1.2 Stacking Small Identical Loads.....	5 - 1
5.1.3 Stacking Large Identical Loads.....	5 - 1
5.2 Lifting the Load.....	5 - 1
5.3 Traveling with the Load.....	5 - 3
5.4 Unloading.....	5 - 4
5.5 Working on Grades.....	5 - 5

---

## **CHAPTER 6 STORING THE FORKLIFT TRUCK**

---

6.1 End of Shift Storage.....	6 - 1
6.2 Long-term Storage.....	6 - 1

---

## **CHAPTER 7 TRANSPORTATION HINTS**

---

7.1 Forklift Truck Shipping.....	7 - 1
7.2 Forklift Truck Lifting and Tiedown Information.....	7 - 1

---

## **CHAPTER 8 SPECIAL SITUATIONS**

---

8.1 Care in Cold Weather.....	8 - 1
8.1.1 Battery.....	8 - 1
8.2 Care in Hot Weather.....	8 - 1
8.2.1 Hot Weather Battery Service.....	8 - 1

8.3 Cold Storage Specifications.....	8 - 1
8.3.1 Description of the Environment and Operation of the Forklift Trucks.....	8 - 1
8.4 Care in Severe Dust or Lint Conditions.....	8 - 2

**CHAPTER 9 MAINTENANCE**

---

9.1 General.....	9 - 1
9.2 Inspection Precautions.....	9 - 2
9.3 Maintenance Schedule.....	9 - 3
9.3.1 Maintenance Schedule - Overview.....	9 - 3
9.3.2 Pre-start Inspection.....	9 - 3
9.3.3 Service Intervals.....	9 - 4
9.4 Every 10 Service Hours or Daily (Pre-Start), Whichever Comes First.....	9 - 5
9.5 Every 50 Service Hours or Weekly, Whichever Comes First.....	9 - 7
9.6 One Month After Delivery of Forklift Truck .....	9 - 7
9.7 Every 1000 Service Hours or 6 Months, Whichever Comes First.....	9 - 7
9.8 Every 2000 Service Hours or 12 Months, Whichever Comes First.....	9 - 8
9.9 Ready to Operate.....	9 - 8
9.9.1 Now Your Forklift Truck is Ready to Operate.....	9 - 8
9.10 Hydraulics.....	9 - 8
9.10.1 Hydraulic Oil Level (Forklift Truck Level) Check.....	9 - 8
9.10.2 Check the Hydraulic Oil Level.....	9 - 9
9.10.3 Adding Hydraulic Oil.....	9 - 11
9.11 Battery .....	9 - 11
9.11.1 Battery Specific Gravity Check.....	9 - 11
9.11.2 Battery Electrolyte Level Check.....	9 - 11
9.11.3 Removing or Installing Battery Gates.....	9 - 12
9.11.4 Removing the Battery.....	9 - 12
9.11.5 Installing the Battery.....	9 - 13
9.11.6 Charging the Battery.....	9 - 13

**CHAPTER 10 SERVICE DATA**

---

10.1 Refill Capacities.....	10 - 1
10.2 Battery Compartment Dimensions.....	10 - 1
10.3 Lubrication Chart.....	10 - 2
10.4 Fluids.....	10 - 3
10.5 Electrical Fuses.....	10 - 3
10.5.1 Checking the Electrical Fuses.....	10 - 3
10.6 Usage Conditions.....	10 - 4
10.7 Forklift Truck Weights.....	10 - 5

**CHAPTER 11 TO THE MITSUBISHI FORKLIFT TRUCK OWNER**

---

11.1 Instructions for Ordering Parts.....	11 - 1
11.2 To the Mitsubishi Forklift Truck Owner.....	11 - 2
11.3 Transfer of Ownership Report for Mitsubishi Customers Only.....	11 - 3



## **Chapter 1 Safety Rules for Forklift Truck Operators**

### **1.1 GENERAL**

The safety rules and regulations in this section are representative of some, but not all rules and regulations apply to forklift trucks. Rules are paraphrased without representation and have been reproduced verbatim.

Your forklift truck was manufactured in accordance with the National Fire Protection Association (NFPA) No. 505 and the American National Standards Institute, Inc. / Industrial Truck Standards Development Foundation (ANSI/ITSDF) B56.1, Safety Standard for Low and High Lift Trucks. Operate this forklift truck in accordance with local regulations.

See [www.itsdf.org](http://www.itsdf.org) web site for more information on the B56.1 Safety Standards for Low Lift and High Lift Trucks.

The most effective way of reducing the risk of serious injuries, or even death, to you and others, is for you to know how to operate the forklift truck properly. Drive alertly and avoid maneuvers or conditions that could cause accidents.

As the operator, you are responsible for the safe operation of this forklift truck.

Be professional.

DO NOT operate a forklift truck if it is in need of maintenance, repair or appears to be unsafe in any way. Report all unsafe conditions immediately to your supervisor, then contact your authorized forklift truck dealer.

DO NOT attempt any adjustments or repairs unless you are trained and authorized to do so.

Continuing improvement and advancement of product design may have caused changes to your forklift truck, which are not included in this publication. Whenever a question arises regarding your forklift truck, or this publication, please contact your authorized forklift truck dealer for the latest available information.

All forklift truck users should be familiar with their Local, Regional, and National regulations. United States users should be familiar with the Occupational Safety and Health Administration (OSHA), and ANSI/ITSDF B56.1, Safety Standard for Low and High Lift Trucks.

See [www.osha.gov](http://www.osha.gov) web site for more information on Regulations (Standards – 29 CFR) Powered industrial trucks – 1910.178.

You should also be familiar with areas of use of different types of forklift trucks as specified in the National Fire Protection Association (NFPA) 505.

## 1.2 OPERATING ENVIRONMENT

### WARNING

#### Warehouse Rack Configuration

This forklift truck model needs to be carefully evaluated for use in warehouse environments where the rack design introduces potential hazards associated with horizontal rack-beam (crossbar) underride.

Horizontal rack-beam underride and potential rack-beam intrusion into the operator's compartment of a stand-up end control forklift truck traveling in tight confines in the "reverse," or "forks-trailing," direction is a recognized potential hazard, due to the rack system design in certain warehouses. Specifically, the potential for rack underride is created by a horizontal rack-beam positioned at a height that the beam can "fit" between the top of the unit's chassis/frame and the bottom of its overhead guard, and there are no corresponding ground level racks or guard rails.

On July 27, 2009, the U.S. Department of Labor's Occupational Safety and Health Administration ("OSHA") published an important Safety and Health Information Bulletin ("SHIB") specifically addressing this potential hazard. This bulletin, entitled "Standup Forklift Under-Ride Hazards" (the "SHIB"), is available for review at <https://www.osha.gov/dts/shib/shib072709.pdf>.

Always look in the direction of travel and have a clear view of the area ahead. Never drive into another object.

If you see horizontal rack-beams that could introduce a potential rack-beam intrusion, **immediately** notify your employer and provide them with the above OSHA SHIB information

### WARNING

At the time this product was originally sold, it's configuration was determined by the owner based on their specific performance and work environment needs. As new potential hazards may be introduced to the work environment it's extremely important that the user, employer and operator work together to continuously evaluate that environment and be rigorous in identifying any new hazards and implementing all available control measures to remove or minimize the risk.

A key resource is your local dealer.

If you or your workplace safety engineers or consultants are concerned about potential hazards in the workplace involving the use of forklift trucks, we encourage you to contact your local dealer who can advise you about various optional accessories available that may help you minimize such potential risk in your application.

Don't wait! Evaluate your forklift truck and work environment today and contact your local dealer if you think there are potential hazards that need to be discussed further. To find an MCFA dealer near you visit [www.mcfa.com](http://www.mcfa.com).

## 1.3 LOCATION OF WARNING AND SAFETY DECALS

There are several specific warning decals on your forklift truck. Their exact location and description of the potential hazard are reviewed in this section. Please take the time to familiarize yourself with these decals.

Be sure you can read all warning and instruction decals. If you cannot, clean or replace them. Use soap and water to clean them.

You must replace a decal if it is damaged, missing or cannot be read. If a decal is on a part that is replaced, make sure a new decal is placed on the new part. Contact your dealer for new decals.

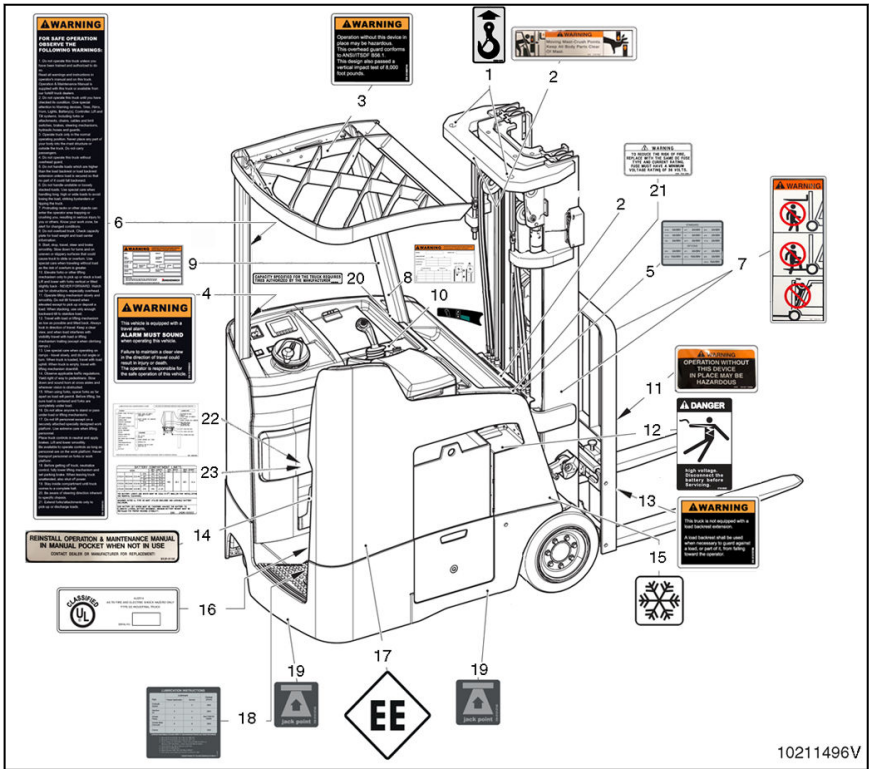

10211496V

- |                                        |                                                 |                                       |
|----------------------------------------|-------------------------------------------------|---------------------------------------|
| 1. ATTACHMENT POINTS DECAL             | 9. NAMEPLATE                                    | 17. EE DECAL                          |
| 2. PINCH POINT WARNING DECAL           | 10. MULTI-FUNCTION CONTROL HANDLE DECAL         | 18. LUBRICATION INSTRUCTIONS          |
| 3. OVERHEAD GUARD IMPACT WARNING DECAL | 11. OPERATION WITHOUT THIS DEVICE WARNING DECAL | 19. JACK POINT DECAL                  |
| 4. ALARM WILL SOUND WARNING DECAL      | 12. HIGH VOLTAGE DANGER DMECAL                  | 20. CAPACITY DECAL                    |
| 5. FUSE DECAL                          | 13. LOAD BACKREST EXTENSION WARNING DECAL       | 21. FUSE WARNING DECAL                |
| 6. GENERAL WARNING DECAL               | 14. RE-INSTALL MANUAL DECAL                     | 22. LUBRICATION AND MAINTENANCE CHART |
| 7. LOAD FORKS AND MAST WARNING DECAL   | 15. COLD STORAGE DECAL                          | 23. BATTERY COMPARTMENT LIMITS        |
| 8. LOAD CAPACITY PLATE                 | 16. UL DECAL                                    |                                       |

## 1.4 DESCRIPTION OF DANGER, WARNING, AND CAUTION DECALS

### 1.4.1 LOAD FORKS AND MAST WARNING DECAL

#### WARNING

- DO NOT stand or ride on the forks.
- DO NOT stand or ride on a load or pallet on the forks.
- DO NOT stand or walk under the forks.
- DO NOT place any part of your body between the mast and the chassis.



1.4.2 GENERAL WARNING DECAL

 **WARNING**

**FOR SAFE OPERATION OBSERVE THE FOLLOWING WARNINGS:**

1. Do not operate this forklift truck unless you have been trained and authorized to do so. Read all warnings and instructions in operator's manual and on this forklift truck. Operation and Maintenance Manual is supplied with this forklift truck or available from our dealers.
2. Do not operate this forklift truck until you have checked its condition. Give special attention to Warning devices, Tires, Rims, Horn, Lights, Battery(s), Contoller, Lift and Tilt systems, including forks or attachments, chains, cables and limit switches, brakes, steering mechanisms, fuel system, hydraulic hoses and guards.
3. Operate forklift truck only in the normal operating position. Never place any part of your body into the mast structure or outside the forklift truck. Do not carry passengers.
4. Do not operate this forklift truck without overhead guard.
5. Do not handle loads which are higher than the load backrest or load backrest extension unless load is secured so that no part of it could fall backward.
6. Do not handle unstable or loosely stacked loads. Use special care when handling long, high or wide loads to avoid losing the load, striking bystanders, or tipping the forklift truck.
7. Protruding racks or other objects can enter the operator area trapping or crushing you, resulting in serious injury to you or others. Know your work zone, be alert for changed conditions
8. Do not overload forklift truck. Check capacity plate for load weight and load center information.
9. Start, stop, travel, steer and brake smoothly. Slow down for turns and on uneven or slippery surfaces that could cause forklift truck to slide or overturn. Use special care when traveling without load as the risk of overturn is greater.
10. Elevate forks or other lifting mechanism only to pick up to stack a load. Lift and lower with mast vertical or tilted slightly back—NEVER FORWARD. Watch out for obstructions, especially overhead.
11. Operate tilting mechanism slowly and smoothly. Do not tilt forward when elevated except to pick up or deposit a load. When stacking, use only enough backward tilt to stabilize load.
12. Travel with load or lifting mechanism as low as possible and tilted back. Always look in direction of travel. Keep a clear view, and when load interferes with visibility travel with load or lifting mechanism trailing (except when climbing ramps).
13. Use special care when operating on ramps—travel slowly, and do not angle or turn. When forklift truck is loaded, travel with load uphill. When forklift truck is empty, travel with lifting mechanism downhill.

 **WARNING**

**FOR SAFE OPERATION OBSERVE THE FOLLOWING WARNINGS:**

1. Do not operate this truck unless you have been trained and authorized to do so.
- Read all warnings and instructions in operator's manual and on this truck. Operation & Maintenance Manual is supplied with this truck or available from our forklift truck dealers.
2. Do not operate this truck until you have checked its condition. Give special attention to Warning devices, Tires, Rims, Horn, Lights, Battery(s), Controller, Lift and Tilt systems, including forks or attachments, chains, cables and limit switches, brakes, steering mechanisms, hydraulic hoses and guards.
3. Operate truck only in the normal operating position. Never place any part of your body into the mast structure or outside the truck. Do not carry passengers.
4. Do not operate this truck without overhead guard.
5. Do not handle loads which are higher than the load backrest or load backrest extension unless load is secured so that no part of it could fall backward.
6. Do not handle unstable or loosely stacked loads. Use special care when handling long, high or wide loads to avoid losing the load, striking bystanders or tipping the truck.
7. Protruding racks or other objects can enter the operator area trapping or crushing you, resulting in serious injury to you or others. Know your work zone, be alert for changed conditions.
8. Do not overload truck. Check capacity plate for load weight and load center information.
9. Start, stop, travel, steer and brake smoothly. Slow down for turns and on uneven or slippery surfaces that could cause truck to slide or overturn. Use special care when traveling without load as the risk of overturn is greater.
10. Elevate forks or other lifting mechanism only to pick up or stack a load. Lift and lower with forks vertical or tilted slightly back - NEVER FORWARD. Watch out for obstructions, especially overhead.
11. Operate tilting mechanism slowly and smoothly. Do not tilt forward when elevated except to pick up or deposit a load. When stacking, use only enough backward tilt to stabilize load.
12. Travel with load or lifting mechanism as low as possible and tilted back. Always look in direction of travel. Keep a clear view, and when load interferes with visibility travel with load or lifting mechanism trailing (except when climbing ramps).
13. Use special care when operating on ramps - travel slowly, and do not angle or turn. When truck is loaded, travel with load uphill. When truck is empty, travel with lifting mechanism downhill.
14. Observe applicable traffic regulations. Yield right of way to pedestrians. Slow down and sound horn at cross aisles and whenever you are obstructed.
15. When using forks, space forks as far apart as load will permit. Before lifting, be sure load is centered and forks are completely under load.
16. Do not allow anyone to stand or pass under load or lifting mechanisms.
17. Do not lift personnel except on a securely attached specially designed work platform. Use extreme care when lifting personnel. Place truck controls in neutral and apply brakes. Lift and lower smoothly. Be available to operate controls as long as personnel are on the work platform. Never transport personnel on forks or work platform.
18. Before getting off truck, neutralize controls, fully lower lifting mechanism and set parking brake. When leaving truck unattended, also shut off power.
19. Stay inside compartment until truck comes to a complete halt.
20. Be aware of steering direction inherent to specific chassis.
21. Extend forks/attachments only to pick-up or discharge loads.

14. Observe applicable traffic regulations. Yield right of way to pedestrians. Slow down and sound horn at cross aisles and wherever vision is obstructed.
15. When using forks, space forks as far as part as load will permit. Before lifting, be sure load is centered and forks are completely under load.
16. Do not allow anyone to stand or pass under load or lifting mechanisms.
17. Do not lift personnel except on a securely attached specially designed work platform. Use extreme care when lifting personnel. Place forklift truck controls in neutral and apply brakes. Lift and lower smoothly. Be available to operate controls as long as personnel are on the work platform. Never transport personnel on forks or work platform.
18. Before getting off forklift truck, neutralize control, fully lower lifting mechanism and set parking brake. When leaving forklift truck unattended, also shut off power.
19. Stay inside compartment until forklift truck comes to a complete halt.
20. Be aware of steering direction inherent to specific chassis.
21. Extend forks/attachments only to pick up or discharge loads.

1.4.3 ALARM MUST SOUND DECAL

**⚠ WARNING**

This vehicle is equipped with a travel alarm.  
**ALARM MUST SOUND** when operating this vehicle.

Failure to maintain a clear view in the direction of travel could result in injury or death.  
The operator is responsible for the safe operation of this vehicle.

**⚠ WARNING**

This vehicle is equipped with a travel alarm.  
**ALARM MUST SOUND** when operating this vehicle.

Failure to maintain a clear view in the direction of travel could result in injury or death.  
The operator is responsible for the safe operation of this vehicle.

EN 51338843

1.4.4 OVERHEAD GUARD IMPACT DECAL

**⚠ WARNING**

Operation without this device in place may be hazardous.  
This overhead guard conforms to ANSI/ITSDF B56.1.  
This design also passed a vertical impact test of 8,000 foot pounds.

**⚠ WARNING**

Operation without this device in place may be hazardous.  
This overhead guard conforms to ANSI/ITSDF B56.1.  
This design also passed a vertical impact test of 8,000 foot pounds.

EN 51380744

1.4.5 PINCH POINT DECAL

**⚠ WARNING**

Moving mast-crush points. Keep all body parts clear of mast.

1.4.6 HIGH VOLTAGE DANGER DECAL

**⚠ WARNING**

High Voltage. Disconnect the battery before servicing.

### 1.4.7 LOAD BACKREST EXTENSION WARNING DECAL

**⚠ WARNING**

This forklift truck is not equipped with a load backrest extension.

A load backrest shall be used when necessary to guard against a load, or parts of it, from falling toward the operator.

**⚠ WARNING**

This truck is not equipped with a load backrest extension.

A load backrest shall be used when necessary to guard against a load, or part of it, from falling toward the operator.

EN 5167426

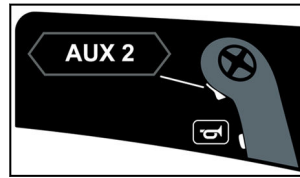

#### Fork Positioner Decal - P/N 51704215

- Shipped from factory when a fork positioner is configured.
- “Aux 2” button is used to spread the forks outward and inward. Move the switch to the left to move the forks inward. Move the switch to the right to move the forks outward.
- For future expansion to this functionality, contact your servicing dealer.

### 1.4.8 WARNING OPERATION WITHOUT THIS DEVICE DECAL

**⚠ WARNING**

Operation without this device in place may be hazardous.

**⚠ WARNING**

OPERATION WITHOUT THIS DEVICE IN PLACE MAY BE HAZARDOUS

ENG 93181-12800

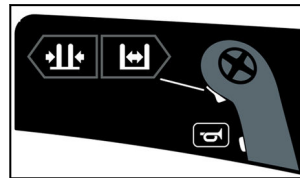

#### Push and Pull Decal - P/N 517042195

- When equipped with Push and Pull – type attachments, ensure proper multi-function control handle decal is used.
- “Aux 2” button is used to push out and pull in the attachment.
- Verify the “Aux Lock Option” parameter is properly set.
- Parameter setting accomplished via laptop using Truck Tool by trained service professional if needed.
- Move the switch to the left to pull in the attachment. Move the switch to the right to push out the attachment.
- For future expansion to this functionality, contact your servicing dealer.

### 1.4.9 MULTI-FUNCTION CONTROL HANDLE DECALS

#### Standard Decal - P/N 51656110a

- Shipped standard from factory when equipped with or without a side shifter.
- “Aux 2” button not used, but available if a secondary auxiliary function is needed for future expansion.
- Contact your servicing dealer for details on expanding “Aux 2” functionality.



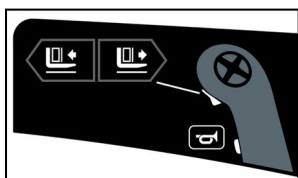

**Clamp Decal - P/N 51704222**

- When equipped with a Clamp attachment, ensure proper multi-function control handle decal is used.
- “Aux2” button is used to clamp and release a load. Move the switch to the left and then push the multi-function control handle forward to clamp the load. Move the switch to the right and then push the multi-function control handle forward to release the load.
- Note that the multi-function control handle must return to neutral between clamp and unclamp functions.
- For future expansion of this functionality, contact your servicing dealer.

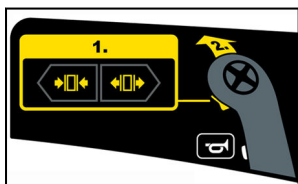

**1.4.10 FUSE LABEL DECAL**

STANDARD					
2F16	5A/58V	4F7	2A/58V	6F6	2A/58V
1F13	5A/58V	F4	2A/58V	4F8	2A/58V
F25	2A/58V	SF11	2A/58V	1F12	2A/58V
OPTIONS					
6F9	2A/58V	SF1	2A/58V	SF7	2A/58V
5F2.2	10A/58V	SF2.1	10A/58V	6F9	2A/58V
				SF2.3	10A/58V

STANDARD					
2F16	5A/58V	4F7	2A/58V	6F6	2A/58V
1F13	5A/58V	F4	2A/58V	4F8	2A/58V
F25	2A/58V	SF11	2A/58V	1F12	2A/58V
OPTIONS					
6F9	2A/58V	SF1	2A/58V	SF7	2A/58V
5F2.2	10A/58V	SF2.1	10A/58V	6F9	2A/58V
				5F2.3	10A/58V

**1.4.11 LUBRICATION INSTRUCTIONS DECAL**

**LUBRICATION INSTRUCTIONS**

Part	Lubricant		Period (Hours)
	Freezer Application	Normal	
Hydraulic System	1	2	2000
Gearbox Oil	3	4	2000
Grease Points	5	5	See OMM for details
Grease Mast Channels	6	6	2000
Chains	7	7	1000

**Lubricant Descriptions (Consult OMM For Recommended Brands and Detail Information)**

- Mobil DTE 10 EXCEL 15 or Renolin MR 310
- Mobil DTE 10 EXCEL 22 or Renolin LIFT 22
- Shell Omala Oil 100 (50%) + Shell Tellus S2 MA 10 (50%) or Renolin CLP 100 (50%) + Shell Tellus S2 MA 10 (50%)
- Shell Omala Oil 100 or Renolin CLP 100
- Mobil Ronex MP NLGI 2
- Mobil Grease XHP 460 (462 Moly) NGLI2
- CAT Chain and Cable Lubricant or Tunfluid LT 220

Consult factory for unusual operating conditions.

# CHAPTER 1 SAFETY RULES FOR FORKLIFT TRUCK OPERATORS

LUBRICATION INSTRUCTIONS				
Part	Lubricant		Period (Hours)	
	Freaser Application	Normal		
Hydraulic System	1	2	2000	
Gearbox Oil	3	4	2000	
Grease Points	5	5	See OMM for details	
Grease Mast Channels	6	6	2000	
Chains	7	7	1000	

Lubricant Descriptions Consult OMM For Recommended Brands and Detail Information

1 - Mobil DTE 15 EXCEL 15 or Reynolds MR 310  
2 - Mobil DTE 15 EXCEL 22 or Reynolds LFT 22  
3 - Shell Omala S2 100 (90%) + Shell Tellus S2 MA 10 (50%) or  
Reynolds CLP 100 (90%) + Shell Tellus S2 MA 10 (50%)  
4 - Shell Omala S2 100 or Reynolds C.P. 100  
5 - Mobil Grease MP NLGI 3  
6 - Mobil Grease MP NLGI 462 (462 Nasty) NGLG  
7 - CAT Chain and Cable Lubricant or Turfball LT 220

Consult Factory For Special Operating Conditions

## 1.4.12 UL DECAL

Classified UL®

AU2514  
AS TO FIRE AND ELECTRIC SHOCK HAZARD  
ONLY  
TYPE EE INDUSTRIAL TRUCK

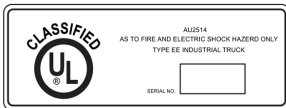

## 1.4.13 REINSTALL MANUAL DECAL

Reinstall operation & maintenance manual in manual pocket when not in use.

Contact dealer or manufacturer for replacement.



## 1.4.14 NAMEPLATE

52		53		54		55	
<b>WARNING</b> IMPROPER OPERATION OR MAINTENANCE COULD RESULT IN INJURY OR DEATH							
MODEL		SERIAL NO.					
RATED CAPACITY		LOAD CENTER DISTANCE					
NET WEIGHT EXCL. BATTERY +/- 5%		ATTACHMENT					
BATTERY VOLTAGE		MAX BATTERY CAPACITY		HOUR RATE		BATTERY	
BATTERY WEIGHT MINIMUM		BATTERY WEIGHT MAXIMUM					
MANUFACTURER							
MADE IN USA		WITHstands TESTS PER SAE DESIGN SPEC. FOR INDUSTRIAL TRUCKS WITH TYPE "E" CAPACITY		IF CAPACITY OF BATTERY MANUFACTURE		XXXXXXXXXX	
SEE INSTRUCTIONS FOR TYPE "E" AND "E" IN ACCORDANCE TO PRECIPROCA		ONS IN PLACE ON DATE					
63		64		65			

102114101

Item	Designation	Item	Designation
52	Type	59	Hour rate
53	Rated capacity	60	Max. battery weight in kg/lb
54	Net weight excl battery +/-5%	61	Manufacturer
55	Serial number	62	Manufacturer's logo
56	Load center distance	63	Battery voltage
57	Attachment	64	Min. battery weight in kg/lb
58	Battery ID	65	Max. battery capacity in Ah

**NOTE:** When making inquiries about the forklift truck or ordering spare parts, please indicate the serial number (55).

## 1.4.15 CAPACITY PLATE

Improper operation or maintenance could result in injury or death. DO NOT operate or work on the forklift truck unless you are properly trained.

66		67	
<b>WARNING</b> IMPROPER OPERATION OR MAINTENANCE COULD RESULT IN INJURY OR DEATH			
MODEL		SERIAL NO.	
LOAD CENTER			
A-HORIZONTAL			
B-VERTICAL			
D-OFFSET		MAST-VERTICAL	
C-FORK HEIGHT		CAPACITY	
mm		kg lbs	
71		72	

102114100

Item	Designation	Item	Designation
66	Type	70	Load center D-Offset
67	Serial number	71	B-Fork height
68	Load center A-Horizontal	72	Capacity
69	Load center B-Vertical		

1.4.16 FUSE WARNING DECAL

**⚠ WARNING**

To reduce the risk of fire, replace with the same DC fuse type and current rating. Fuse must have a minimum voltage rating of 36 Volts.

**⚠ WARNING**

TO REDUCE THE RISK OF FIRE,  
REPLACE WITH THE SAME DC FUSE  
TYPE AND CURRENT RATING.  
FUSE MUST HAVE A MINIMUM  
VOLTAGE RATING OF 36 VOLTS.

EN9 4281-0050

1.4.17 CAPACITY DECAL

**⚠ WARNING**

Capacity specified for forklift truck requires tires authorized by the manufacturer.

**CAPACITY SPECIFIED FOR THE TRUCK REQUIRES  
TIRES AUTHORIZED BY THE MANUFACTURER**

EN9 4281-0050

1.4.18 LUBRICATION AND MAINTENANCE CHART

Be sure to perform service items quoted on decal.

**NOTE:** Reduce servicing intervals in dusty or severe conditions.

LUBRICATION AND MAINTENANCE CHART		SEE USER'S MANUAL SERVICE INTERVAL QUOTED BELOW
<p><b>CHECK</b></p> <ul style="list-style-type: none"> <li>1. TIGHTENING OF SKIRT</li> <li>2. TIRE</li> <li>3. LIFT CHASSIS</li> <li>4. LIFT CHASSIS</li> <li>5. LIFT CHASSIS</li> <li>6. LIFT CHASSIS</li> <li>7. LIFT CHASSIS</li> <li>8. LIFT CHASSIS</li> <li>9. LIFT CHASSIS</li> <li>10. LIFT CHASSIS</li> <li>11. LIFT CHASSIS</li> <li>12. LIFT CHASSIS</li> <li>13. LIFT CHASSIS</li> <li>14. LIFT CHASSIS</li> <li>15. LIFT CHASSIS</li> <li>16. LIFT CHASSIS</li> <li>17. LIFT CHASSIS</li> <li>18. LIFT CHASSIS</li> <li>19. LIFT CHASSIS</li> <li>20. LIFT CHASSIS</li> <li>21. LIFT CHASSIS</li> <li>22. LIFT CHASSIS</li> <li>23. LIFT CHASSIS</li> <li>24. LIFT CHASSIS</li> <li>25. LIFT CHASSIS</li> <li>26. LIFT CHASSIS</li> <li>27. LIFT CHASSIS</li> <li>28. LIFT CHASSIS</li> <li>29. LIFT CHASSIS</li> <li>30. LIFT CHASSIS</li> <li>31. LIFT CHASSIS</li> <li>32. LIFT CHASSIS</li> <li>33. LIFT CHASSIS</li> <li>34. LIFT CHASSIS</li> <li>35. LIFT CHASSIS</li> <li>36. LIFT CHASSIS</li> <li>37. LIFT CHASSIS</li> <li>38. LIFT CHASSIS</li> <li>39. LIFT CHASSIS</li> <li>40. LIFT CHASSIS</li> <li>41. LIFT CHASSIS</li> <li>42. LIFT CHASSIS</li> <li>43. LIFT CHASSIS</li> <li>44. LIFT CHASSIS</li> <li>45. LIFT CHASSIS</li> <li>46. LIFT CHASSIS</li> <li>47. LIFT CHASSIS</li> <li>48. LIFT CHASSIS</li> <li>49. LIFT CHASSIS</li> <li>50. LIFT CHASSIS</li> <li>51. LIFT CHASSIS</li> <li>52. LIFT CHASSIS</li> <li>53. LIFT CHASSIS</li> <li>54. LIFT CHASSIS</li> <li>55. LIFT CHASSIS</li> <li>56. LIFT CHASSIS</li> <li>57. LIFT CHASSIS</li> <li>58. LIFT CHASSIS</li> <li>59. LIFT CHASSIS</li> <li>60. LIFT CHASSIS</li> <li>61. LIFT CHASSIS</li> <li>62. LIFT CHASSIS</li> <li>63. LIFT CHASSIS</li> <li>64. LIFT CHASSIS</li> <li>65. LIFT CHASSIS</li> <li>66. LIFT CHASSIS</li> <li>67. LIFT CHASSIS</li> <li>68. LIFT CHASSIS</li> <li>69. LIFT CHASSIS</li> <li>70. LIFT CHASSIS</li> <li>71. LIFT CHASSIS</li> <li>72. LIFT CHASSIS</li> <li>73. LIFT CHASSIS</li> <li>74. LIFT CHASSIS</li> <li>75. LIFT CHASSIS</li> <li>76. LIFT CHASSIS</li> <li>77. LIFT CHASSIS</li> <li>78. LIFT CHASSIS</li> <li>79. LIFT CHASSIS</li> <li>80. LIFT CHASSIS</li> <li>81. LIFT CHASSIS</li> <li>82. LIFT CHASSIS</li> <li>83. LIFT CHASSIS</li> <li>84. LIFT CHASSIS</li> <li>85. LIFT CHASSIS</li> <li>86. LIFT CHASSIS</li> <li>87. LIFT CHASSIS</li> <li>88. LIFT CHASSIS</li> <li>89. LIFT CHASSIS</li> <li>90. LIFT CHASSIS</li> <li>91. LIFT CHASSIS</li> <li>92. LIFT CHASSIS</li> <li>93. LIFT CHASSIS</li> <li>94. LIFT CHASSIS</li> <li>95. LIFT CHASSIS</li> <li>96. LIFT CHASSIS</li> <li>97. LIFT CHASSIS</li> <li>98. LIFT CHASSIS</li> <li>99. LIFT CHASSIS</li> <li>100. LIFT CHASSIS</li> </ul>	<p><b>CHANGE</b></p> <ul style="list-style-type: none"> <li>1. OIL</li> <li>2. OIL</li> <li>3. OIL</li> <li>4. OIL</li> <li>5. OIL</li> <li>6. OIL</li> <li>7. OIL</li> <li>8. OIL</li> <li>9. OIL</li> <li>10. OIL</li> <li>11. OIL</li> <li>12. OIL</li> <li>13. OIL</li> <li>14. OIL</li> <li>15. OIL</li> <li>16. OIL</li> <li>17. OIL</li> <li>18. OIL</li> <li>19. OIL</li> <li>20. OIL</li> <li>21. OIL</li> <li>22. OIL</li> <li>23. OIL</li> <li>24. OIL</li> <li>25. OIL</li> <li>26. OIL</li> <li>27. OIL</li> <li>28. OIL</li> <li>29. OIL</li> <li>30. OIL</li> <li>31. OIL</li> <li>32. OIL</li> <li>33. OIL</li> <li>34. OIL</li> <li>35. OIL</li> <li>36. OIL</li> <li>37. OIL</li> <li>38. OIL</li> <li>39. OIL</li> <li>40. OIL</li> <li>41. OIL</li> <li>42. OIL</li> <li>43. OIL</li> <li>44. OIL</li> <li>45. OIL</li> <li>46. OIL</li> <li>47. OIL</li> <li>48. OIL</li> <li>49. OIL</li> <li>50. OIL</li> <li>51. OIL</li> <li>52. OIL</li> <li>53. OIL</li> <li>54. OIL</li> <li>55. OIL</li> <li>56. OIL</li> <li>57. OIL</li> <li>58. OIL</li> <li>59. OIL</li> <li>60. OIL</li> <li>61. OIL</li> <li>62. OIL</li> <li>63. OIL</li> <li>64. OIL</li> <li>65. OIL</li> <li>66. OIL</li> <li>67. OIL</li> <li>68. OIL</li> <li>69. OIL</li> <li>70. OIL</li> <li>71. OIL</li> <li>72. OIL</li> <li>73. OIL</li> <li>74. OIL</li> <li>75. OIL</li> <li>76. OIL</li> <li>77. OIL</li> <li>78. OIL</li> <li>79. OIL</li> <li>80. OIL</li> <li>81. OIL</li> <li>82. OIL</li> <li>83. OIL</li> <li>84. OIL</li> <li>85. OIL</li> <li>86. OIL</li> <li>87. OIL</li> <li>88. OIL</li> <li>89. OIL</li> <li>90. OIL</li> <li>91. OIL</li> <li>92. OIL</li> <li>93. OIL</li> <li>94. OIL</li> <li>95. OIL</li> <li>96. OIL</li> <li>97. OIL</li> <li>98. OIL</li> <li>99. OIL</li> <li>100. OIL</li> </ul>	<p><b>LUBRICATE</b></p> <ul style="list-style-type: none"> <li>1. LUBRICATE</li> <li>2. LUBRICATE</li> <li>3. LUBRICATE</li> <li>4. LUBRICATE</li> <li>5. LUBRICATE</li> <li>6. LUBRICATE</li> <li>7. LUBRICATE</li> <li>8. LUBRICATE</li> <li>9. LUBRICATE</li> <li>10. LUBRICATE</li> <li>11. LUBRICATE</li> <li>12. LUBRICATE</li> <li>13. LUBRICATE</li> <li>14. LUBRICATE</li> <li>15. LUBRICATE</li> <li>16. LUBRICATE</li> <li>17. LUBRICATE</li> <li>18. LUBRICATE</li> <li>19. LUBRICATE</li> <li>20. LUBRICATE</li> <li>21. LUBRICATE</li> <li>22. LUBRICATE</li> <li>23. LUBRICATE</li> <li>24. LUBRICATE</li> <li>25. LUBRICATE</li> <li>26. LUBRICATE</li> <li>27. LUBRICATE</li> <li>28. LUBRICATE</li> <li>29. LUBRICATE</li> <li>30. LUBRICATE</li> <li>31. LUBRICATE</li> <li>32. LUBRICATE</li> <li>33. LUBRICATE</li> <li>34. LUBRICATE</li> <li>35. LUBRICATE</li> <li>36. LUBRICATE</li> <li>37. LUBRICATE</li> <li>38. LUBRICATE</li> <li>39. LUBRICATE</li> <li>40. LUBRICATE</li> <li>41. LUBRICATE</li> <li>42. LUBRICATE</li> <li>43. LUBRICATE</li> <li>44. LUBRICATE</li> <li>45. LUBRICATE</li> <li>46. LUBRICATE</li> <li>47. LUBRICATE</li> <li>48. LUBRICATE</li> <li>49. LUBRICATE</li> <li>50. LUBRICATE</li> <li>51. LUBRICATE</li> <li>52. LUBRICATE</li> <li>53. LUBRICATE</li> <li>54. LUBRICATE</li> <li>55. LUBRICATE</li> <li>56. LUBRICATE</li> <li>57. LUBRICATE</li> <li>58. LUBRICATE</li> <li>59. LUBRICATE</li> <li>60. LUBRICATE</li> <li>61. LUBRICATE</li> <li>62. LUBRICATE</li> <li>63. LUBRICATE</li> <li>64. LUBRICATE</li> <li>65. LUBRICATE</li> <li>66. LUBRICATE</li> <li>67. LUBRICATE</li> <li>68. LUBRICATE</li> <li>69. LUBRICATE</li> <li>70. LUBRICATE</li> <li>71. LUBRICATE</li> <li>72. LUBRICATE</li> <li>73. LUBRICATE</li> <li>74. LUBRICATE</li> <li>75. LUBRICATE</li> <li>76. LUBRICATE</li> <li>77. LUBRICATE</li> <li>78. LUBRICATE</li> <li>79. LUBRICATE</li> <li>80. LUBRICATE</li> <li>81. LUBRICATE</li> <li>82. LUBRICATE</li> <li>83. LUBRICATE</li> <li>84. LUBRICATE</li> <li>85. LUBRICATE</li> <li>86. LUBRICATE</li> <li>87. LUBRICATE</li> <li>88. LUBRICATE</li> <li>89. LUBRICATE</li> <li>90. LUBRICATE</li> <li>91. LUBRICATE</li> <li>92. LUBRICATE</li> <li>93. LUBRICATE</li> <li>94. LUBRICATE</li> <li>95. LUBRICATE</li> <li>96. LUBRICATE</li> <li>97. LUBRICATE</li> <li>98. LUBRICATE</li> <li>99. LUBRICATE</li> <li>100. LUBRICATE</li> </ul>

1.4.19 BATTERY COMPARTMENT LIMITS

The battery length and width must be 12mm (0.5 in.) smaller for installation and removal clearance.

Machines rated UL Type EE must utilize enclosed and lockable battery enclosure.

Side battery set screw must be tightened against the battery to eliminate lateral battery movement. Minimum battery weight must be installed for proper machine stability.

BATTERY COMPARTMENT LIMITS									
MODEL	MAX. LENGTH		MAX. WIDTH		MAX. HEIGHT		MAX. WEIGHT		N
	MIN.	MAX.	MIN.	MAX.	MIN.	MAX.	MIN.	MAX.	
ET0214	FRCS14N	ECS14N	STD.	382	14.25				
			OPT.	413	15.25				
ET0216	FRCS16N	ECS16N	STD.	464	18.25	900	38.5	805	31.6
			OPT.	413	15.25				
ET0318	FRCS18N	ECS18N	STD.	540	21.25				

THE BATTERY LENGTH AND WIDTH MUST BE 12mm (0.5") SMALLER FOR INSTALLATION AND REMOVAL CLEARANCE.

MACHINES RATED UL TYPE EE MUST UTILIZE ENCLOSED AND LOCKABLE BATTERY ENCLOSURE.

SIDE BATTERY SET SCREW MUST BE TIGHTENED AGAINST THE BATTERY TO ELIMINATE LATERAL BATTERY MOVEMENT. MINIMUM BATTERY WEIGHT MUST BE INSTALLED FOR PROPER MACHINE STABILITY.

EN9 4281-00500

1.5 SAFETY RULES

**⚠ WARNING**



D00369

1. CERTIFICATE

**Authorized and trained operators only!**

DO NOT operate this forklift truck unless you have a certificate for operating this type of forklift truck and have the ability to operate the forklift truck safely.

**⚠ WARNING**



**Fire hazards!**

Always charge the battery in a well-ventilated area. Flammable gas comes out of the battery while charging. DO NOT smoke, keep flames away. DO NOT use equipment that is liable to produce sparks in this area.

**⚠ WARNING**



D00651

**Dress properly for the job!**

Follow your employer guidelines for protective equipment.

DO NOT wear loose clothing or accessories (flapping cuffs, dangling chains, necktie, scarves, or rings) that could catch in moving parts.

Wear personal protective equipment appropriate for the conditions of your work places.

**⚠ WARNING**

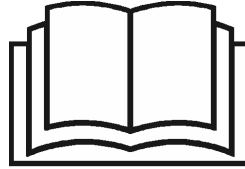

D00682

**Know your forklift truck and attachments!**

Read and understand the operating, inspection, and maintenance instructions in the Operation & Maintenance Manual attachment vendor manuals and the decals on the forklift truck.

Reinstall the Operation and Maintenance Manual in the manual pocket when not in use. Contact dealer or manufacturer for replacement.

**⚠ WARNING**

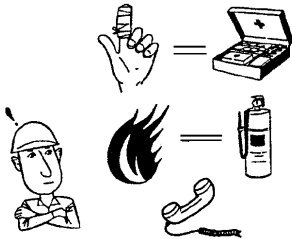

D00279

**Always be alert!**

Know how to use a first aid kit and a fire extinguisher, and where to get prompt assistance.

**⚠ WARNING**



100607B

**Know all signals and traffic rules!**

Know who is responsible for signaling. Learn to tell at a glance what the signal means, and what action you should take.

**⚠ WARNING**

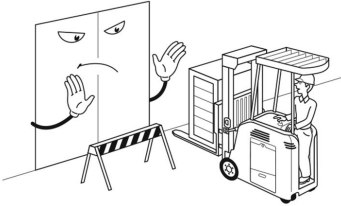

10-1

**Operate only in approved areas!**

Certain areas such as those containing hazardous flammable gases, liquid or other combustibles require a Safety Rated forklift truck. If your forklift truck is not Safety Rated, the area must be avoided.

**⚠ WARNING**

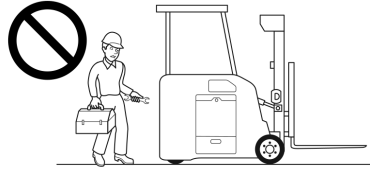

10-2

**DO NOT add to or modify your forklift truck!**

Modifications and additions which affect capacity and safe operation shall not be performed by the customer or user without manufacturer's prior written approval. Capacity, operation, and maintenance instruction plates, tags, or decals shall be changed accordingly.

Only in the event that the forklift truck manufacturer is no longer in business and there is no successor in the interest to the business, may the user arrange for a modification or alteration to a forklift truck, provided, however, that the user.

- Arranges for the modification or alteration to be designed, tested and implemented by an engineer(s) expert in forklift truck and their safety
- Maintains a permanent record of the design, test(s) and implementation of the modification or alteration
- Approves and makes appropriate changes to the capacity plate(s), decals, tags and instruction handbook
- Affixes a permanent and readily visible label to the forklift truck stating the manner in which the forklift truck has been modified or altered, together with the date of the modification or alteration and the name and address of the organization that accomplished those tasks

**⚠ DANGER**

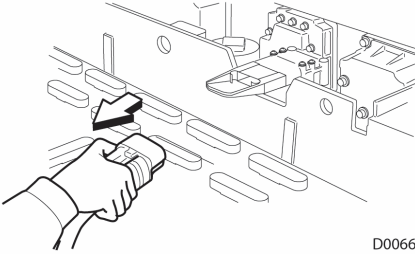

D00661

**Service electrical system safety!**

NEVER service a forklift truck while battery is connected.

Turn the key switch to the OFF position.

Disconnect the battery plug/connector.

Contact your authorized dealer if required.

**⚠ WARNING**



970023

**Always protect against acid burns!**

Battery acid may burn. Protect yourself before servicing, changing or charging the battery.

**⚠ WARNING**

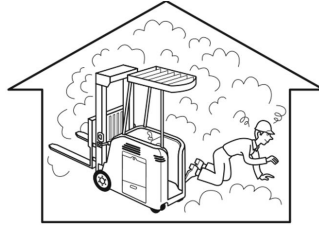

11\_1

**Explosion Hazard!**

Explosive gases are generated when batteries are being charged. Always ensure adequate ventilation for battery charging. Do not smoke, keep flames and sparks away.

**⚠ WARNING**

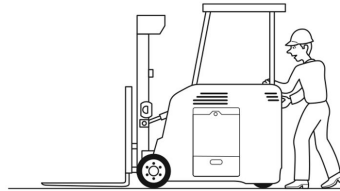

11\_4

**Inspect your forklift truck prior to operation!**

At the beginning of each shift, fill out a daily inspection sheet. Defects when found must be immediately reported and corrected before operating the forklift truck, or the forklift truck must be taken out of service.

**⚠ WARNING**



12\_3

**DO NOT remove the overhead guard!**

The overhead guard is intended to offer protection from the impact of small packages, boxes, bagged material, etc., representative of the job application, but not to withstand the impact of a falling capacity load.

**⚠ WARNING**

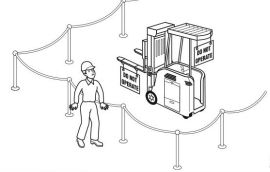

20\_2

**DO NOT operate a damaged or defective forklift truck!**

If the forklift truck is damaged, take it out of service until it has been restored to safe operating conditions.

Park it in a non-operating area and remove the key. Attach a "DO NOT OPERATE" or similar warning tag to the forklift truck.

Contact your authorized dealer for repairs.

**⚠ WARNING**

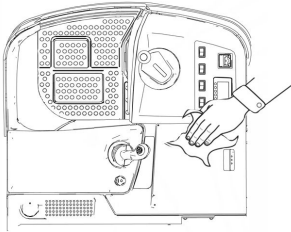

12\_1V

**Keep operator compartment clean!**

Keep your hands and shoes, as well as the floor, and controls (steering wheel, multi-function control handle, operator presence and traction pedals) clean and free of grease, mud and other materials. A slip may cause an accident.

**⚠ WARNING**

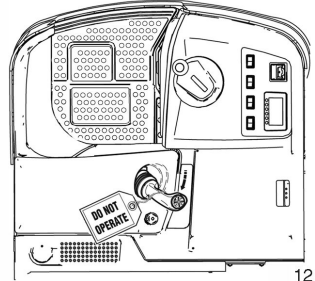

12\_2VA

**DO NOT operate an unsafe forklift truck!**

If the forklift truck has an "OUT OF SERVICE" or similar warning tag, the forklift truck must not be operated until it has been restored to a safe operating condition. Inspect a forklift truck before you operate it to be sure that it is properly maintained and in good working order.

**⚠ WARNING**



D00692

**Handle batteries carefully!**

- Battery acid will burn skin, eat holes in clothing and cause blindness if splashed into eyes.
- If you spill acid on yourself, flush skin immediately with lots of water. Apply baking soda to help neutralize the acid.
- If acid gets in your eyes, flush them immediately with large amounts of water and see a doctor at once.

**⚠ WARNING**

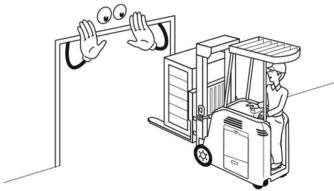

15\_4

**Always check overhead clearance!**

Serious accidents could be caused by the mast and overhead guard hitting pipes, beams or other overhead obstructions.

**⚠ WARNING**

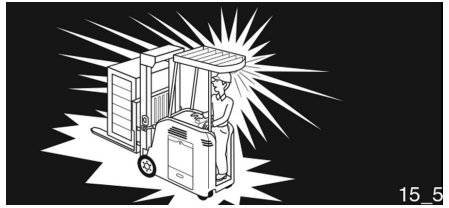

15\_5

**Use lights in dark, dim areas!**

Even with lights on, do not assume that people see you and will move out of your way. Sound horn where appropriate.

**⚠ WARNING**

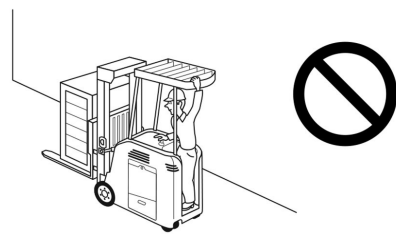

0\_3

**Stay under the overhead guard!**

DO NOT hold on to the overhead guard.

**⚠ WARNING**

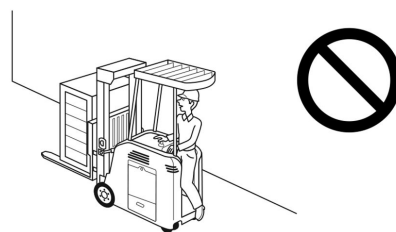

0\_1

**Stay within the confines of the forklift truck!**

Keep your arms, feet, legs etc. inside the operator's compartment. DO NOT put any part of the body outside the operator compartment of the forklift truck.



**⚠ WARNING**



16\_2

**Always be aware of floor capacity!**

Make sure the floor will support the weight of the loaded forklift truck.

**⚠ WARNING**

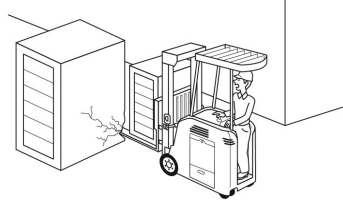

18\_1

**Be careful of forks that extend beyond the load!**

If the forks extend beyond the load, use extra caution. Make sure the fork tips DO NOT contact other material.

**⚠ WARNING**



100924

**Be careful of changes in capacity!**

- Know the capacity when attachments are used. Extra care must be taken in securing, manipulating, positioning, and transporting the load. Operate forklift trucks equipped with attachments as partially loaded forklift truck when not handling loads.
- When using an attachment, BE SURE to read the attachment instructions manual and attachment warning labels carefully and understand its function fully before using it.

**⚠ WARNING**

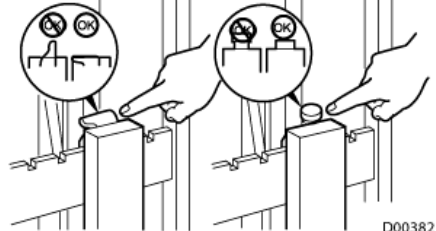

D00382

**Check fork pins for engagement!**

If the fork pins are not properly engaged, the forks can get out of position. This may cause loads or forklift truck to become unstable.

**⚠ WARNING**



19\_5

**Always stay healthy on the job!**

Always stay healthy on the job. Forklift truck operators must be qualified as to visual, auditory, physical, and mental ability to operate the forklift truck safely.

**NEVER** operate the forklift truck under the influence of drugs or alcohol that may impair your ability to properly operate the forklift truck.

**⚠ WARNING**



D00726V

**Operate the forklift truck safely within the rules and regulations of your employer!**

**⚠ WARNING**

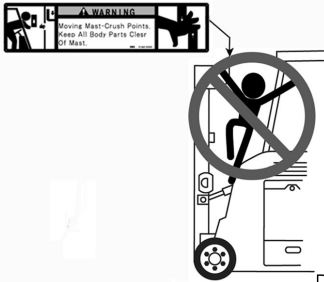

D00689V

**Stay clear of pinch points!**

Keep all parts of your body away from moving parts such as the mast, carriage and attachments. **DO NOT** place any part of your body between the overhead guard and the mast. If the mast moves unexpectedly, you could get caught between the mast and overhead guard and a serious accident could occur.

**⚠ WARNING**



D00725A

**DO NOT** operate the forklift truck if you are pregnant or have suffered an abdominal disease or injury.

**⚠ WARNING**

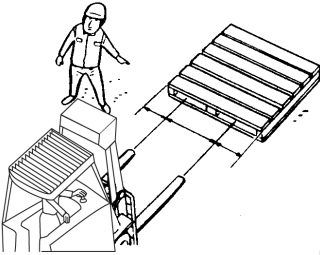

D00303V

**Avoid off-center loading!**

Set the forks as far apart as possible for maximum support of the pallet or load. Too small of forks spread could cause instability of the load. **DO NOT** pick up an off-center load.

**⚠ WARNING**

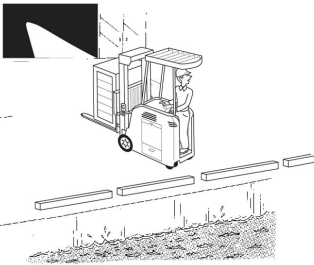

D00297V

**Check work places for high risk!**

When working on docks, ramps, platforms and other high-risk areas, use adequate blocks to reduce the risk of the forklift truck from falling off.

**⚠ WARNING**

During operation, do not extend any parts of your body outside the operator compartment and never place any part of your body between objects when one of the objects is moving.

Always stay clear of drop-offs and edges (e.g. loading docks).

In the event of an imminent tip-over, or off the dock accident, step off and away from the forklift truck as quickly as possible.

If your forklift truck is equipped with an optional rear operator guard ("door") you need to be aware that while this option offers additional protection in certain applications, where bar-type materials could intrude into the operator's compartment, this option necessarily increases the exit time and thus the potential for serious injury to the operator in emergencies such as tip-over and off-dock accidents, and may create potential shear and pinch points, increase compartment heat, and contribute to operator fatigue.

**⚠ WARNING**

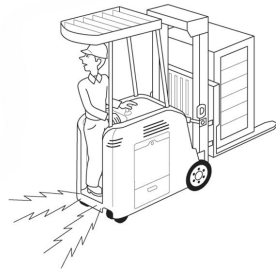

D00374V

**This forklift truck is equipped with a travel alarm. The alarm must sound when operating this forklift truck!**

Make sure the alarm is in working order. The horn can also be used to alert other forklift trucks or pedestrians. Always look in the direction of travel

**⚠ WARNING**



F00074

**Wear a hard hat if recommended or required by your employer or applicable regulations.**

**⚠ WARNING**



F00086V

**DO avoid slippery surfaces!**  
Slow down for wet and slippery surfaces.

**1.6 OPERATING PRECAUTIONS**

**⚠ WARNING**

Read and understand all of the following safety guidelines for maximum operation of the forklift truck.

**⚠ WARNING**

**FOR SAFE OPERATION OBSERVE THE FOLLOWING WARNINGS:**

1. Do not operate this forklift truck unless you have been trained and authorized to do so. Read all warnings and instructions in operator's manual and on this forklift truck. Operation and Maintenance Manual is supplied with this forklift truck or available from our dealers.
2. Do not operate this forklift truck until you have checked its condition. Give special attention to Warning devices, Tires, Rims, Horn, Lights, Battery(s), Controller, Lift and Tilt systems, including forks or attachments, chains, cables and limit switches, brakes, steering mechanisms, fuel system, hydraulic hoses and guards.
3. Operate forklift truck only in the normal operating position. Never place any part of your body into the mast structure or outside the forklift truck. Do not carry passengers.
4. Do not operate this forklift truck without overhead guard.
5. Do not handle loads which are higher than the load backrest or load backrest extension unless load is secured so that no part of it could fall backward.
6. Do not handle unstable or loosely stacked loads. Use special care when handling long, high or wide loads to avoid losing the load, striking bystanders, or tipping the forklift truck.
7. Protruding racks or other objects can enter the operator area trapping or crushing you, resulting in serious injury to you or others. Know your work zone, be alert for changed conditions
8. Do not overload forklift truck. Check capacity plate for load weight and load center information.

9. Start, stop, travel, steer and brake smoothly. Slow down for turns and on uneven or slippery surfaces that could cause forklift truck to slide or overturn. Use special care when traveling without load as the risk of overturn is greater.
10. Elevate forks or other lifting mechanism only to pick up to stack a load. Lift and lower with mast vertical or tilted slightly back—NEVER FORWARD. Watch out for obstructions, especially overhead.
11. Operate tilting mechanism slowly and smoothly. Do not tilt forward when elevated except to pick up or deposit a load. When stacking, use only enough backward tilt to stabilize load.
12. Travel with load or lifting mechanism as low as possible and tilted back. Always look in direction of travel. Keep a clear view, and when load interferes with visibility travel with load or lifting mechanism trailing (except when climbing ramps).
13. Use special care when operating on ramps—travel slowly, and do not angle or turn. When forklift truck is loaded, travel with load uphill. When forklift truck is empty, travel with lifting mechanism downhill.
14. Observe applicable traffic regulations. Yield right of way to pedestrians. Slow down and sound horn at cross aisles and wherever vision is obstructed.
15. When using forks, space forks as far as part as load will permit. Before lifting, be sure load is centered and forks are completely under load.
16. Do not allow anyone to stand or pass under load or lifting mechanisms.
17. Do not lift personnel except on a securely attached specially designed work platform. Use extreme care when lifting personnel. Place forklift truck controls in neutral and apply brakes. Lift and lower smoothly. Be available to operate controls as long as personnel are on the work platform. Never transport personnel on forks or work platform.

18. Before getting off forklift truck, neutralize control, fully lower lifting mechanism and set parking brake. When leaving forklift truck unattended, also shut off power.
19. Stay inside compartment until forklift truck comes to a complete halt.
20. Be aware of steering direction inherent to specific chassis.
21. Extend forks/attachments only to pick up or discharge loads.

**⚠ WARNING**

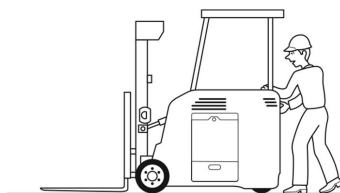

11\_4

**Mounting the forklift truck!**

- When mounting the forklift truck, face the operator compartment.
- Using three-points of contact (one foot and two hands) step into the operator compartment.
- Do not use any of the controls as handholds when entering the operator compartment.
- Never get on or off a moving forklift truck.
- Never jump off or jump on a forklift truck.

**Dismounting the forklift truck!**

- When leaving the operator compartment face the rear of the forklift truck.
- Power down forklift truck before dismounting.
- Do not use any of the controls as handholds when leaving the forklift truck and use three-points of contact.
- Look both ways and down before stepping down from the operator compartment.

**⚠ WARNING**

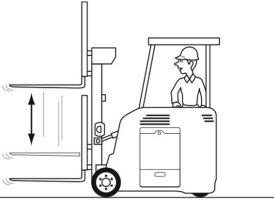

13\_2

**Make sure your forklift truck is in a safe operating condition!**

Test multi-function control handle while moving slowly in a safe area. Make sure the mast moves up and down smoothly.

**⚠ WARNING**

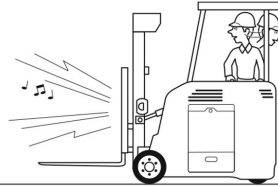

13\_1

**Move your forklift truck safely!**

Make sure that no one is around the forklift truck before starting.

**⚠ WARNING**

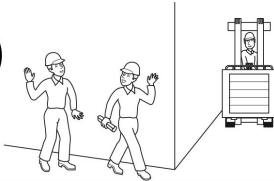

14\_2

**Look where you are going! DO NOT MOVE unless you have good visibility around you.**

- If you sound the horn, people may not even notice. Pay attention to movements of people around you.
- The operator is required to slow down and activate the horn at cross aisles and other locations where vision is obstructed.
- Yield the right of way to pedestrians.

**⚠ WARNING**

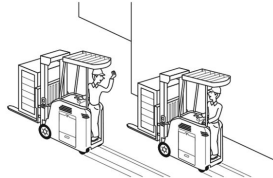

14\_3

**DO NOT pass another forklift truck!**

DO NOT pass another forklift truck traveling in the same direction at intersections, blind spots or at other dangerous locations.

**⚠ WARNING**

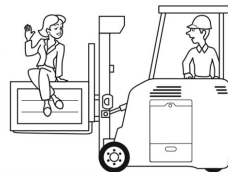

14\_1

**DO NOT allow any riders!**

Do not allow anyone to ride on the forks or on any other part of the forklift truck, at any time.

**⚠ WARNING**

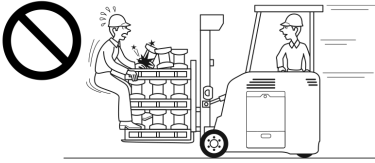

14\_4

**DO NOT allow anyone to hold loads!**

**⚠ WARNING**



14\_5

**Always be aware of people near your forklift truck!**

Always be aware of people near your forklift truck. DO NOT move until they are at a safe distance and are aware of you.

**⚠ WARNING**

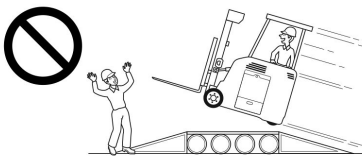

15\_1

**DO NOT engage in stunt driving or horseplay!** Stunt driving and horseplay is hazardous for both the forklift truck operator and fellow workers.

**⚠ WARNING**

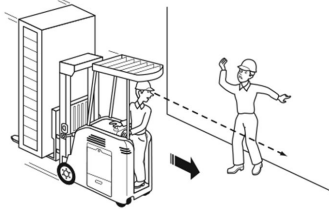

15\_2

**Travel in reverse if forward visibility is blocked! Always face in the direction of travel with load trailing.**

**Failure to maintain a clear view in the direction of travel could result in injury or death.**

For better visibility with large loads, travel in reverse, but always keep a lookout in the direction of travel.

**⚠ WARNING**

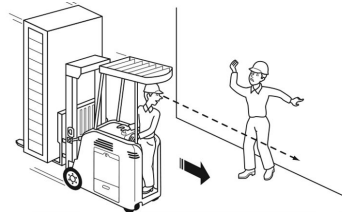

15\_2A

**Always look in the direction of travel with load trailing!**

**⚠ WARNING**



14\_6

**Allow for tail swing distance!**

When turning in aisles, especially narrow aisles, keep as far away as possible from stock and racks. Be cautious near people.

Make sure that personnel stand clear of the rear swing area before making turns.

**⚠ WARNING**

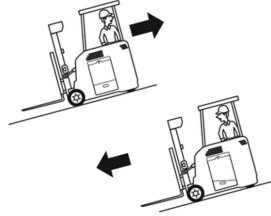

16\_4

**Travel safely on grades with an empty forklift truck!**

When traveling empty, forks shall point down the grade regardless of direction.

**⚠ WARNING**

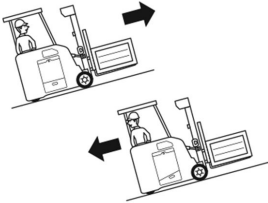

16\_1

**Travel safely on grades with a loaded forklift truck!**

When traveling with a load, load shall always point up the grade regardless of direction.

**⚠ WARNING**

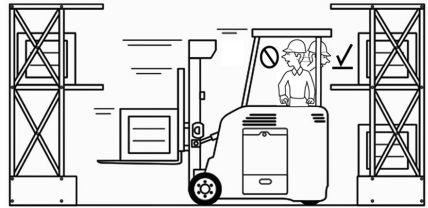

16\_4BV

**Always be aware of your surroundings!**

When using the forklift truck, always look behind you before going in reverse.

Protruding racks or other objects can enter the operator area trapping or crushing you, resulting in serious injury to you or others. Know your work zone, be alert for changed conditions

Do not drive into another object.



**⚠ WARNING**

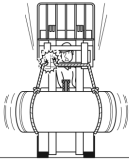

17\_4

**Use forks properly!**

Fork misuse could cause accidents, injuries and damage.

When lifting a load, use the proper attachment designed for the load. **DO NOT** operate at high speeds.

**⚠ WARNING**

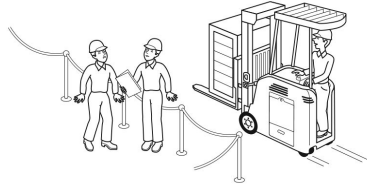

17\_2

**Danger! Keep out!**

- **DO NOT** allow any unauthorized persons in the work area where the forklift truck is operated.
- Personnel must be clear of the forklift truck operating area.

**⚠ WARNING**



46\_1

**Always stay within the capacity!**

Read the capacity plate to make sure a load is within the capacity of your forklift truck before you handle the load.

**⚠ WARNING**



18\_3

**DO NOT move!**

If someone is standing next to your forklift truck, don't move until they are out of the way. Remove your foot from the operator presence pedal to make sure the forklift truck is stationary.

**⚠ WARNING**



17\_1

**DO NOT use damaged pallets!**

Make sure pallets and skids are sturdy and in safe operating condition.

**⚠ WARNING**

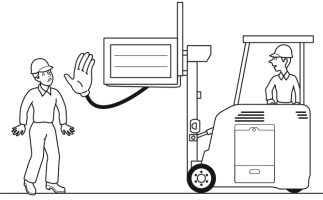

17\_3

**A helper should NOT be near the forklift truck!**  
People should be clear of the forklift truck operating area.

**⚠ WARNING**

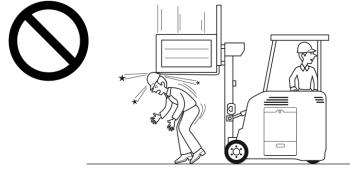

0\_4

**DO NOT allow anyone to walk or stand under raised forks!**

**⚠ WARNING**

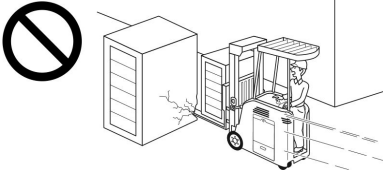

18\_2

**SLOW DOWN and DO NOT speed when approaching loads!**  
Approaching loads at high speed is dangerous. Also, it could damage loads.

Approach the load carefully at slow speeds.  
Approaching loads at high speed is hazardous. Also, it could damage the load.

**⚠ WARNING**



19\_2

**DO NOT allow unloading from raised loads!**  
Failure to follow this rule could cause serious injury.

**⚠ WARNING**

**When lifting a pallet!**

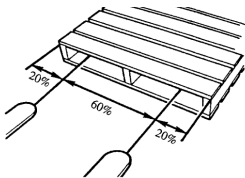

100761

Set the forks as far apart as possible for maximum support of the pallet or load. Too small a fork spread could cause instability of the load.

**⚠ WARNING**

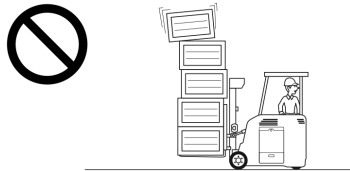

18\_5

**Ensure the load is not too high!**

**DO NOT** pick up unsecured loads that extend above the load backrest extension height.

Do not lift loads without the load backrest as it can be hazardous.

**⚠ WARNING**

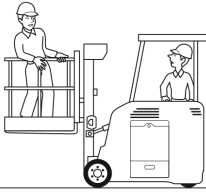

19\_3

**Use only specialized equipment designed to safely raise personnel to high work areas!**

Use extreme care when lifting personnel. Place the mast in the VERTICAL position, place the multi-function control handle in the NEUTRAL position, and apply the parking brake. Lift and lower smoothly. Have a trained operator in position to control the forklift truck as long as personnel are on the work platform. DO NOT transport personnel on forks or work platform.

**⚠ WARNING**

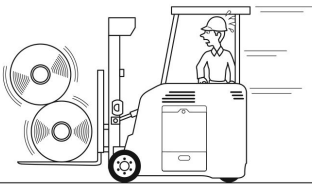

19\_1

**Handle only stable and safely arranged loads!**

If a load is unstable, it could easily shift and fall on someone.

**⚠ WARNING**



19\_4A

**DO NOT abuse your forks!**

Fork misuse could cause accidents, serious injuries, damage to the forklift truck and damage to the load.

**⚠ WARNING**

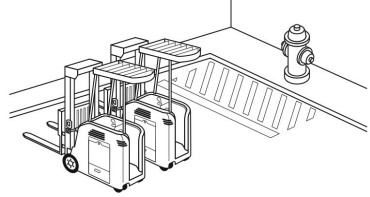

20\_1

**Park in authorized areas only!**

Park a safe distance from access to fire aisles, stairways and fire equipment.

DO NOT park near a flammable material storage area

**⚠ WARNING**

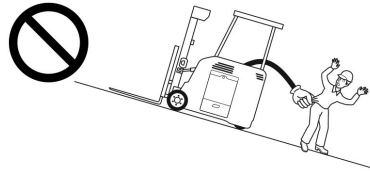

20\_3

**NEVER park this forklift truck on a ramp or grade!**

This could cause the forklift truck to tip over. Before you leave your forklift truck, or park it.

- Fully lower the forks.
- Turn the key switch to the OFF position.
- Push the EPO (Emergency Power Off) button IN.
- Remove the key from the key switch.
- When leaving the forklift truck unattended, disconnect the battery.

**⚠ WARNING**



20\_2

**Parking a disabled machine safely!**

- If the lift mechanism is disabled and the forks cannot be lowered, park the forklift truck in a non-operating area and attach warning tags to the forks to alert pedestrians and traffic.
- Use barriers to prevent anyone from standing or passing under the forks.
- Remove the key and attach DO NOT OPERATE or similar warning tag to the forklift truck.
- Disconnect or remove battery from forklift truck.
- Contact your authorized dealer.

**⚠ WARNING**

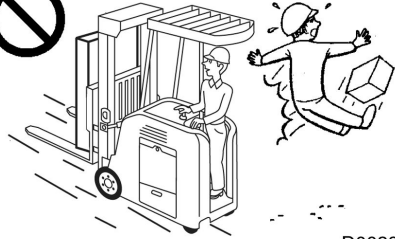

D00384V

**Watch out for pedestrians at all times!**

Yield the right-of-way to pedestrians at all times.

**⚠ WARNING**

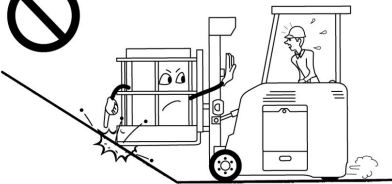

D00317V

**Be particularly careful when driving up or down a steep slope!**

Use extreme care to reduce the risk of fork tips or the bottom of the pallet from touching the ground

**⚠ WARNING**

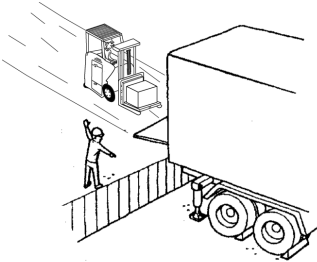

D00343V

**Inspect a trailer before entering!**

- The brakes on the highway trucks or trailers must be applied, and wheel chocks or other positive mechanical means must be used to prevent unintentional movement of highway trucks and trailers.
- DO NOT travel along the edge of the dock. The forklift truck could fall off the dock.
- Before starting work, check the allowable load of dock plate, and if it does not have enough strength to withstand the weight of the forklift truck carrying a load, DO NOT use it.
- When entering a trailer, use outriggers so that trailer will not sink.
- Travel slowly on dock plate when getting in or out of trailers or railroad.
- Ask the driver of the trailer not to move the trailer until the work is completed.
- Use any anchoring equipment available in the dock to secure the trailer or railroad, and also secure the dock plate to prevent it from falling off.
- Obey the instructions of the supervisor when working as a team.

**⚠ WARNING**



D00402V

**Side shifter operation!**

When sideshifting to pick up loads, BE SURE that forks are centered under the load. DO NOT side shift while traveling with loads.

**⚠ WARNING**

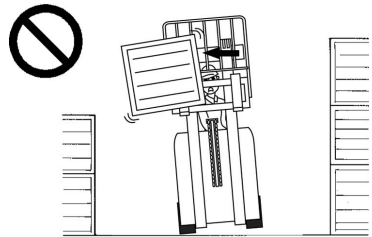

D00403V

**DO NOT raise or lower a load while side shifted, as it is dangerous!**

DO NOT side shift the forks with the load raised higher than 150 cm (59 in.) unless safety is assured by the load stack or carrier deck just below the forks.

**⚠ WARNING**

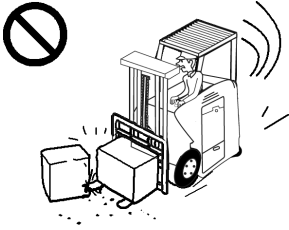

D00727V

**Be careful when turning with a load!**

- When operating with a load, the load or tip of the forks may be hard to see.
- If operated carelessly, the load or forks could collide with nearby objects.
- When making turns while operating in REVERSE with a load, always pay attention to the position of the load. If not, the load could collide with nearby objects.

**⚠ WARNING**

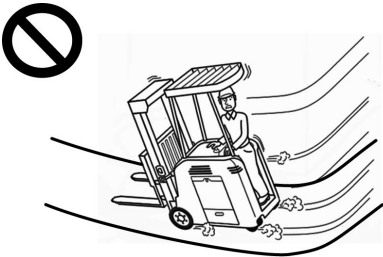

F00071V

**DO NOT make fast or sharp turns with a loaded or unloaded forklift truck!**

When making turns, reduce speed to a safe level consistent with the operating environment.

**⚠ WARNING**

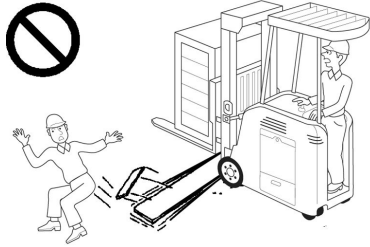

F00082V

**DO NOT run over objects!**  
**DO NOT run over loose objects.**

**⚠ WARNING**

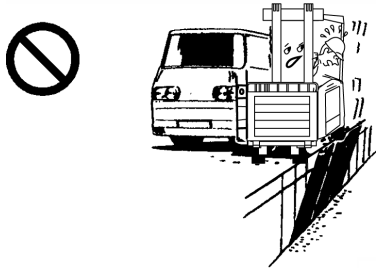

D00083V

**Watch "tail swing!"**

Always maintain a safe distance from the edge of docks, ramps, and platforms. The forklift truck could drop off the edge if you get too close to the edge.

 **WARNING**

During operation, do not extend any parts of your body outside the operator compartment and never place any part of your body between objects when one of the objects is moving.

Always stay clear of drop-offs and edges (e.g. loading docks).

In the event of an imminent tip over, or off the dock accident, step off and away from the forklift truck as quickly as possible.

If your forklift truck is equipped with an optional rear operator guard ("door") you need to be aware that while this option offers additional protection in certain applications, where bar-type materials could intrude into the operator's compartment, this option necessarily increases the exit time and thus the potential for serious injury to the operator in emergencies such as tip-over and off-dock accidents, and may create potential shear and pinch points, increase compartment heat, and contribute to operator fatigue.

## **Chapter 2 Know Your Forklift Truck**

### **2.1 CONTROLS AND INDICATORS**

The operator compartment utilizes controls that permit side stance and a standard open rear design. Side stance permits the operator to turn around and face the direction of travel whether traveling forward or reverse. The compartment also allows the operator to shift body weight and position to maintain maximum comfort. The open rear design minimizes operator fatigue by making it easy to get on and off the forklift truck. It also allows for the quickest exit from the forklift truck—an important safety feature should the forklift truck begin to tip or fall from an elevated height, such as a loading dock or ramp.

Location and function of the controls in the operator compartment are shown on the following pages.



Description of Indicators and Controls

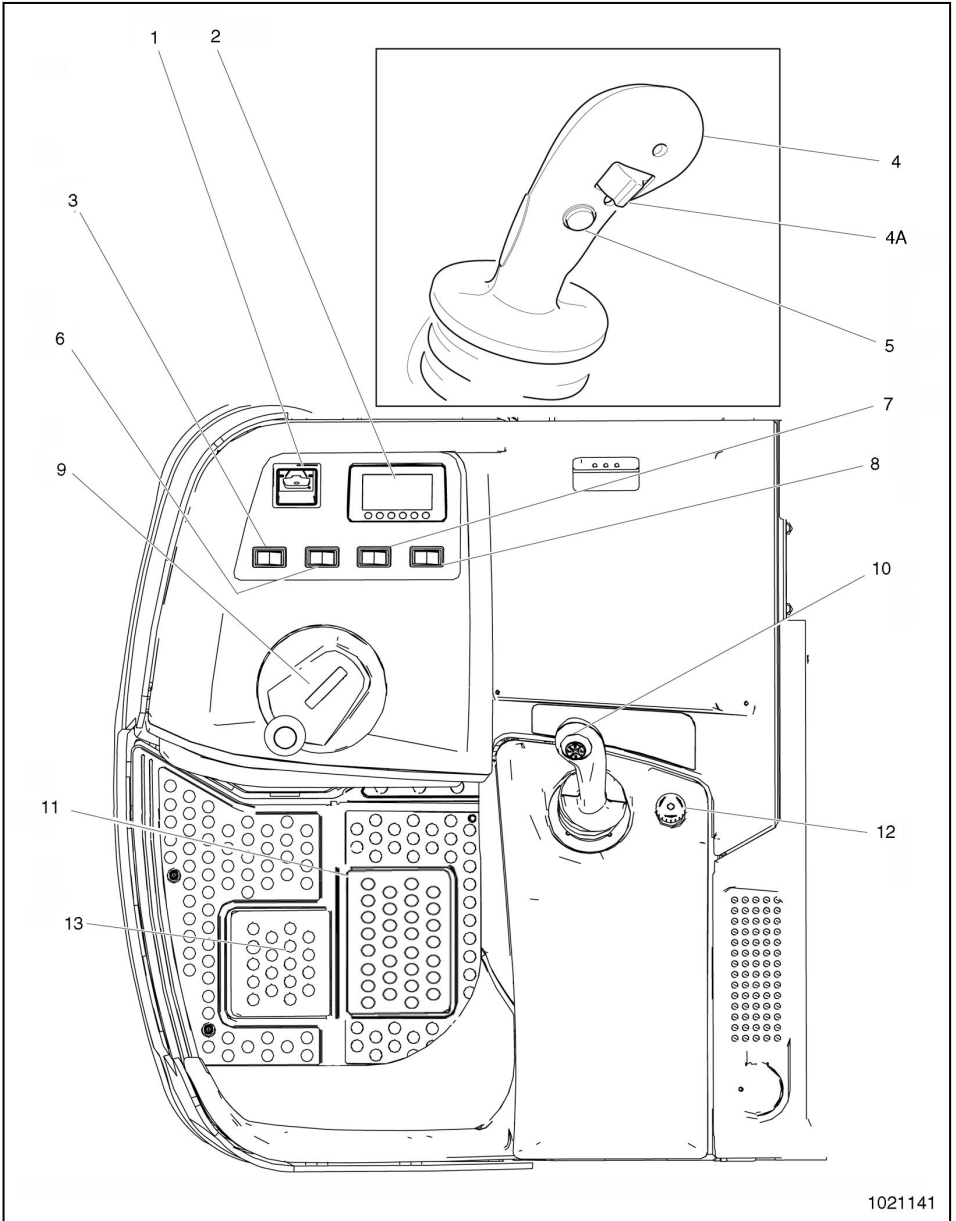

1021141

Item	Control and Display Element	Standard/Optional	Function
1	Key switch	●	Switches control current ON and OFF. Removing the key prevents the forklift truck from being switched ON by unauthorized personnel.
	Code lock	○	Turns the forklift truck ON.
2	Control and display unit	●	Display of steering direction, warning indicators, event messages and mode indicators.
3	Headlight drive direction switch	○	Switches light ON and OFF.
4	Multi-function control handle	●	Operates the following functions: <ul style="list-style-type: none"> <li>- Travel direction forward/reverse</li> <li>- Mast lifting/lowering</li> <li>- Horn button</li> </ul>
4A	AUX 2	○	Shipped standard from factory when equipped with or without a side shifter. Aux 2 button is not used, but available if a secondary auxiliary function is needed. For future expansion to this functionality, contact your servicing dealer. Options are: <ul style="list-style-type: none"> <li>- Fork Positioner Attachment - Used to widen or narrow the fork spread. Move the switch to the left to narrow the fork spread. Move the switch to the right widen the fork spread.</li> <li>- Push Pull Attachment - Used to push out and pull in the attachment. Verify the "Aux Lock Option" parameter is properly set. Parameter setting accomplished via laptop using Truck Tool by trained service professional, if needed. Move the switch to the left to pull in the attachment. Move the switch to the right to push out the attachment.</li> <li>- Clamp Attachment - Used to clamp and release a load. Move the switch to the left and then push the Multi-pilot forward to clamp the load. Move the switch to the right and then push the multi-function control handle forward to release the load. Note that the multi-function control handle must return to neutral between clamp and unclamp functions.</li> </ul>
5	Horn button	●	Activates the horn.
6	Fan switch	○	Switches fan ON and OFF.
7	Operator reading light switch	○	Switches operator light ON and OFF.
8	Headlight fork direction switch	○	Switches light ON and OFF.

**CHAPTER 2 KNOW YOUR FORKLIFT TRUCK**

<b>Item</b>	<b>Control and Display Element</b>	<b>Standard/Optional</b>	<b>Function</b>
9	Steering wheel	●	Travel direction command
10	Cross switch	●	Tilting the forks forward/back. Side shifter to the left / right.
11	Operator presence pedal	●	<ul style="list-style-type: none"> <li>- Pedal pressed down - hydraulic functions fully functional.</li> <li>- Pedal pressed down simultaneously with Traction Pedal - forklift truck fully functional.</li> <li>- Pedal up - Driving and hydraulic functions disabled, forklift truck brakes activated.</li> </ul>
12	EMERGENCY STOP switch	●	Turns the power supply ON and OFF.
13	Traction pedal	●	<ul style="list-style-type: none"> <li>- Pedal pressed down simultaneously with Operator Presence Pedal - forklift truck fully functional.</li> <li>- Pedal up - forklift truck brakes activated.</li> </ul>
	Lever	●	Adjust the adjustable Comfort operator platform to the operator's weight.
●	Standard equipment	○	Optional equipment

Overview of Components

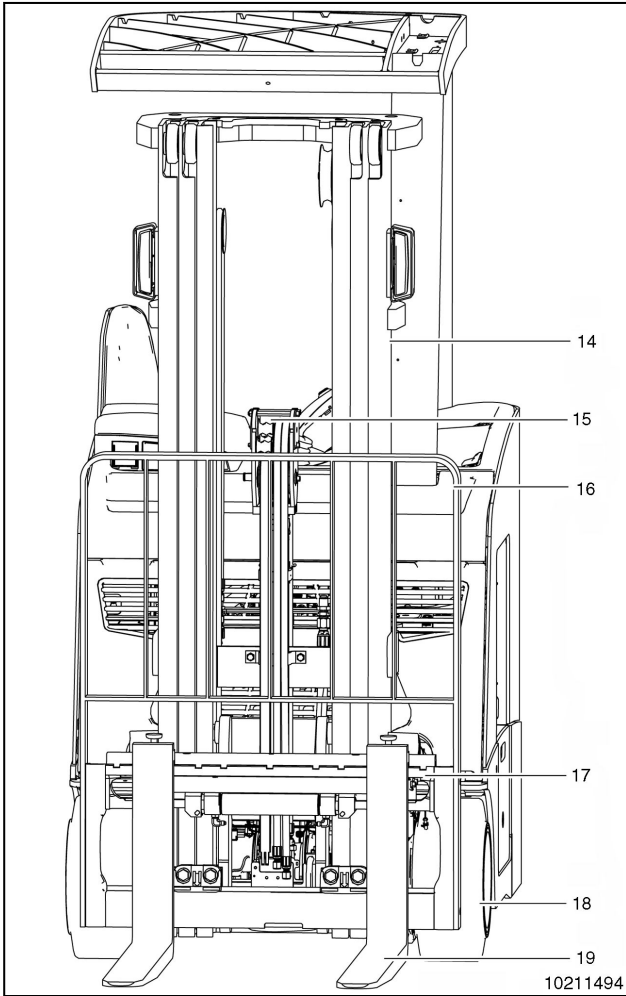





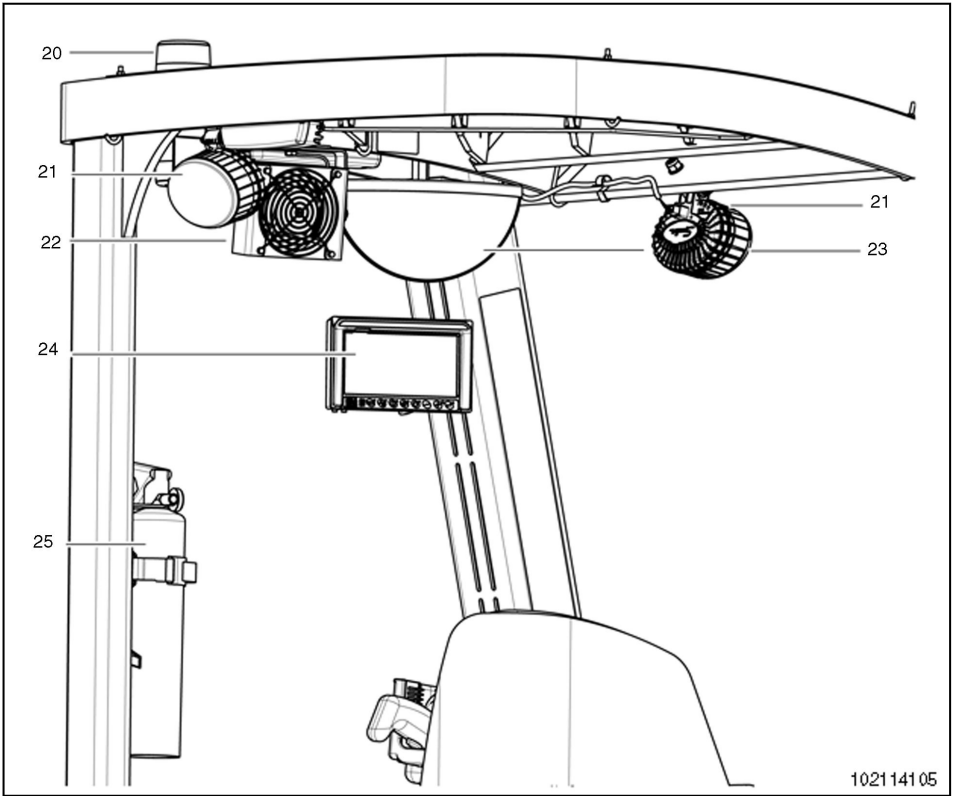



10211494

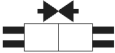



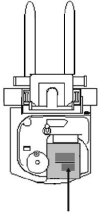

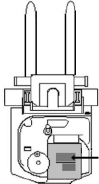

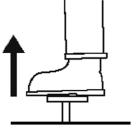

Item		Description	Item		Description
14	●	Mast	17	●	Fork carriage
15	●	Free lift cylinder	18	●	Load wheels
16	●	Load back rest	19	●	Load forks
	●	Standard equipment		○	Optional equipment



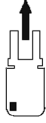

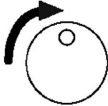
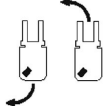

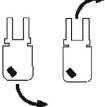
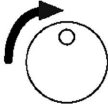
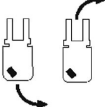

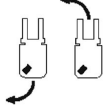

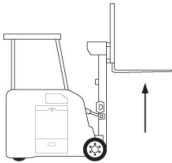

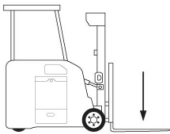
102114105

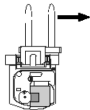
Item		Description	Item		Description
20	○	Warning beacon	23	○	Parabolic mirror
21	○	Floor spot	24	○	Screen
22	○	Fan	25	○	Fire extinguisher
	●	Standard equipment		○	Optional equipment

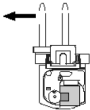
Control	Operator Action	Forklift Truck Response
<p><b>Battery Connector</b></p> <p>Function The Battery disconnect provides a mechanical joint to connect or disconnect from the battery.</p> <p>Activation To connect battery, align mating connector halves and push together. To disconnect battery, pull connector halves apart.</p>		<p>Vehicle is ready for operation</p>
<p><b>Emergency Power Off (EPO) Button</b></p>		<p>Push down to stop all forklift truck function.</p>
<p><b>Key Switch</b></p> <p>(OFF) O      (ON) I</p> 	<p>(OFF) O      (ON) I</p> 	<p>Forklift truck performs SelfTest - then forklift truck is ready for operation.</p>
<p>Function The key switch turns electrical power to control circuits ON or OFF. SelfTest –Then forklift truck is ready for operation</p> <p>Activation To turn power on, rotate key to the right. To turn power OFF, rotate key to the left.</p> <p>In an emergency, press the Emergency Power Off Button located to the right of the multi-function control handle.</p>		
 <p><b>Traction Pedal</b></p>		<ol style="list-style-type: none"> <li>1. Brake is released.</li> <li>2. Travel system is enabled when pressed down simultaneously with Operator Presence Pedal.</li> </ol>
		<ol style="list-style-type: none"> <li>1. Mast Interlock is released.</li> <li>2. Mast system is enabled.</li> <li>3. Brake is released.</li> <li>4. Travel system is enabled when pressed down simultaneously with Traction Pedal.</li> </ol>

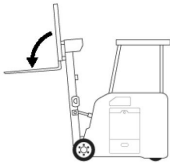
Control	Operator Action	Forklift Truck Response
Operator Presence Pedal		<ol style="list-style-type: none"> <li>1. Mast Interlock is applied.</li> <li>2. Mast system is disabled.</li> <li>3. Brake is applied.</li> <li>4. Travel function is disabled.</li> </ol>
Horn	<p>Press Button</p> 	
Directional/ Speed Control	<p>Move multi-function control handle toward forks to move forklift truck</p> 	
	<p>Move multi-function control handle away from forks to move forklift truck</p> 	
Directional Reverse Steering Control		
		
Directional Forward Steering Control (Optional)		
		

Control	Operator Action	Forklift Truck Response
<p><b>Lift</b></p> 	<p>Pull multi-function control handle back toward the right side of forklift truck to lift forks.</p>	
<p><b>Lower</b></p> 	<p>Push multi-function control handle forward toward left side of forklift truck to lower forks.</p>	
<p><b>Sideshift Right</b> (Optional)</p> 	<p>Press bottom control pad button to sideshift forks right.</p>	
<p><b>Sideshift Left</b> (Optional)</p> 	<p>Press top control pad button to sideshift forks left.</p>	
<p><b>Tilt Mast Forward</b></p> 	<p>Press right control pad button to tilt mast forward.</p>	
<p><b>Tilt Mast Back</b></p> 	<p>Press left control pad button to tilt mast back.</p>	

## 2.2 OPERATOR DISPLAY

### Description

### 2.2.1 DISPLAY UNIT

The display unit represents the operator-forklift truck interface. It acts both as a display and control unit for the operator.



The display unit gives information on the travel direction, steer angle, battery charge condition and other selected forklift truck parameters.

**2.2.2 SETTING THE DISPLAY UNIT**

**2.2.2.1 DISPLAY (4 INCH)**

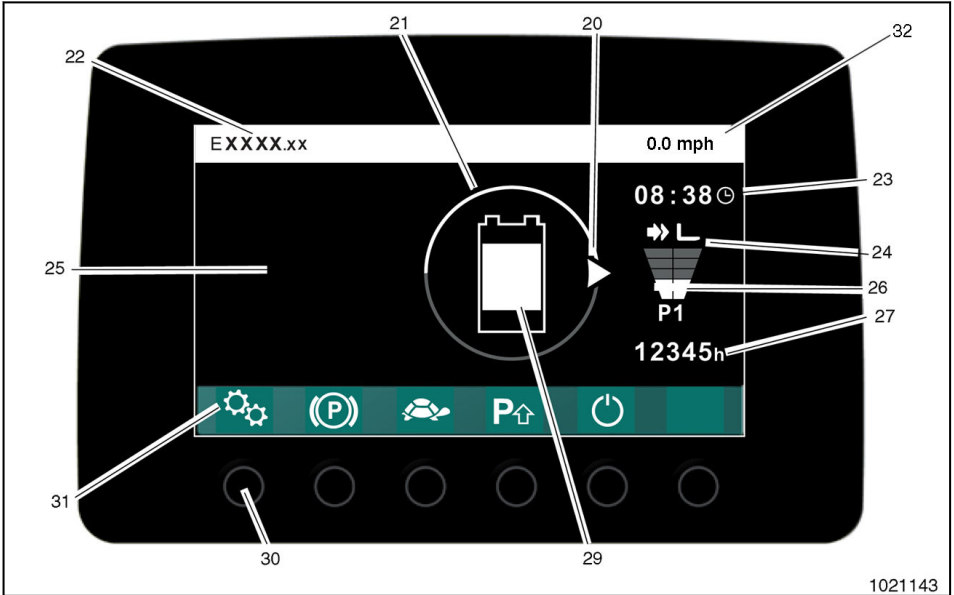









1021143





Item	Control or Display	Function
20	Direction display	The arrow displays the current travel direction of the forklift truck and the current wheel position in 15° segments.
21	Travel direction preselection	Displays the selected travel direction.
22	Information field	Shows event messages and optional information such as speed, lift height, load weight and remaining operating time.
23	Clock	Time display
24	Power display	Shows the available power in the travel program selected.
25	Pictogram field	Displays the pictograms.
26	Operating program	Shows the operating program selected.
27	Hour meter	Operating hours are counted while the forklift truck is operational and the operator presence pedal is activated.
28	Button allocation	See <b>Button Assignment of the Display Unit</b> .
29	Battery capacity display	Battery discharge status
30	Button	Selection button for the corresponding functions
31	Settings	Changes to the menu to administer the codes or transponders
32	MPH display	Shows miles per hour.











### 2.2.2.2 BUTTON ASSIGNMENT OF THE DISPLAY UNIT

#### Main Menu Icons

Symbol	Meaning
	Information field toggle: Allows the information displayed in the information field to be changed.
	Slow travel: Reduced travel speed
	Travel program down: Changes the travel program
	Travel program up: Changes the travel program
	Setting: To change to the menu to administer the codes or transponders
	Switching OFF additional equipment (  ): Switching OFF (  ) is only available in the display if the forklift truck is switched ON with an access code. Switches OFF forklift truck
	Parking Brake: Shows parking brake status.









#### Additional Symbols

Symbol	Meaning
	Lighting (  ): Switches the lighting ON/OFF
	Floor spot (  ): The floor spot projects a colored dot onto the ground 4-4,5 m in front of the forklift truck when driving forwards. The floor spot is intended to make people aware of the route being taken by the forklift truck.

Symbol	Meaning
	Working light ( <input type="radio"/> ): Switches the working light ON/OFF
	Setting ( <input type="radio"/> ): To change to the menu to administer the codes
	Change master code ( <input type="radio"/> ): To change the master code and to activate the keypad
	Edit access code ( <input type="radio"/> ): To add or delete access codes
	Selection up ( <input type="radio"/> ): To choose access codes
	Selection down ( <input type="radio"/> ): To choose access codes
	Delete ( <input type="radio"/> ): To delete access codes selected
	Add ( <input type="radio"/> ): To add a new access code
	Back ( <input type="radio"/> ): Cancels the current procedure and returns to the previous menu.
	Confirm ( <input type="radio"/> ): To confirm an entry

2.2.2.3 SYMBOLS IN THE DISPLAY UNIT



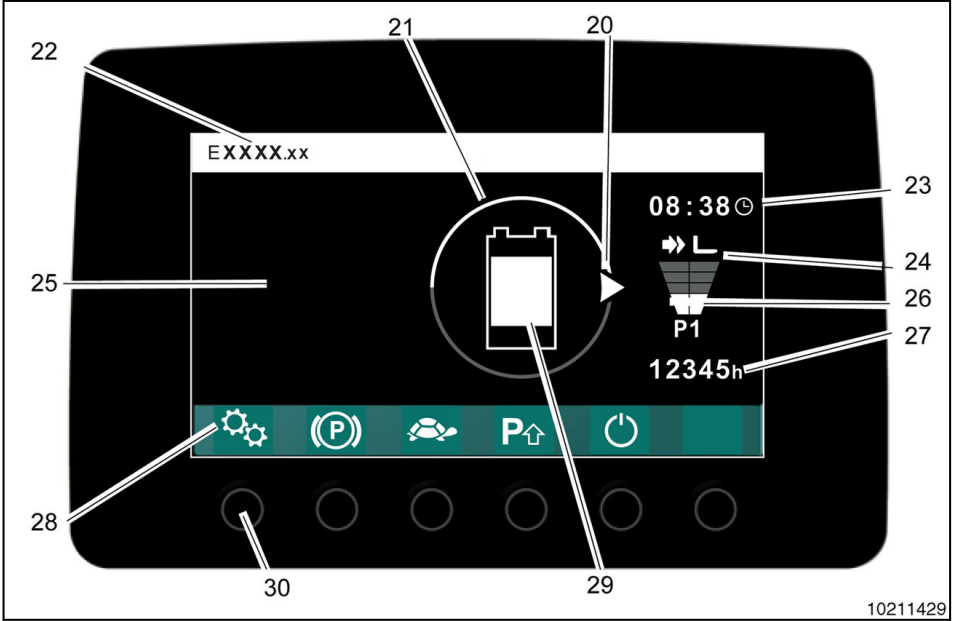

Any number of pictograms can be displayed in the pictogram field (25). Which pictograms appear in the pictogram field during operation depends on the specific operating situation for the forklift truck.

Symbol	Meaning	Color	Function
	Stop notice	red	Functions deactivated due to forklift truck malfunction
	Warning	yellow	Operating error
		red	Forklift truck malfunction
	Operator platform Operator presence pedal	yellow	Operator platform is not occupied and the travel switch is being pressed. (The yellow symbol does not light up if the forklift truck is equipped with pedestrian mode.)
	Service mode indicator	yellow	Maintenance is due, see <b>Maintenance Section</b>
		red	Safety inspection is due see <b>Safety Section</b>
	Battery capacity display	yellow	Battery capacity $\leq$ 30%
		red	Battery capacity $\leq$ 20%
	Overheat indicator	yellow	Lifting, lowering and travel speeds reduced due to overtemperature.
		red	Lifting, lowering and travel functions disabled due to overtemperature.
	Slow travel	green	Reduced travel speed
	Parking Brake	red	Parking brake set.
		green	Parking brake released.

2.2.2.4 SETTING THE TIME



10211429

Symbol	Procedure
	Press setting.
	Press clock.
	Set the time by pressing the selection down / up.
	Press confirm to move to the next digit or to confirm the time.

### 2.2.3 KEYLESS ACCESS SYSTEMS

Keyless access systems give the operator or operator group the option of assigning individual PIN codes.

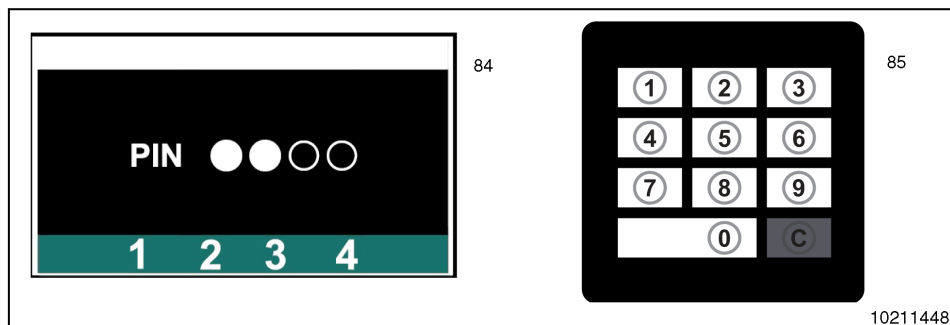

Item	Description
84	Display unit (EasyAccess softkey): <ul style="list-style-type: none"> <li>- Description, see <b>Setting the Display Unit</b></li> <li>- Entry 4-place master code and access code</li> <li>- Storage locations for a maximum of 10 access codes</li> <li>- For master and access codes consisting of the numbers 1 to 4</li> </ul>
85	Keypad (EasyAccess PIN Code): <ul style="list-style-type: none"> <li>- Consisting of keys 0 to 9 and C (delete)</li> <li>- Entry 4-place master code and access code</li> <li>- Storage locations for a maximum of 100 access codes</li> </ul>

#### 2.2.4 GENERAL INFORMATION ABOUT OPERATION WITH KEYLESS ACCESS SYSTEMS

The delivery code is identified by an adhesive label. Change the master code of the forklift truck during initial startup and remove the film.

- Delivery code: 1-2-3-4
- Factory setting master code: 2-4-1-2

**NOTE:** After a valid code is entered or a valid transponder is used, a green check mark appears in the display unit. After an invalid code is entered or an invalid transponder is used, a red x appears and the entry must be repeated.

**NOTE:** After the forklift truck is idle for a certain amount of time, the display unit switches into standby mode. Press any button or key to end standby mode.

#### 2.2.5 OPERATING THE KEYPAD

**NOTE:** The following settings can also be made by the dealer.

##### 2.2.5.1 TURNING ON THE FORKLIFTRUCK WITH AN ACCESS CODE

1. Release the EMERGENCY STOP switch, see **Emergency Stop**.
2. Enter the access code with the keypad (85).

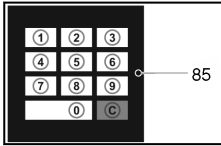

85. KEYPAD

The forklift truck is turned on.

2.2.5.2 TURNING OFF THE FORKLIFT TRUCK

1. Activate the button under the "Turn off" icon (86) in the display unit.
2. Press the EMERGENCY STOP switch, see **Emergency Stop**.



86. TURN OFF ICON

The forklift truck is turned off.

2.2.5.3 CHANGING THE MASTER CODE

1. Switch forklift truck on.
2. Press the button under the "Setting" icon (87).

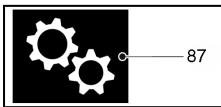

87. SETTING ICON

3. Press the button under the "Change master code" icon (88).



88. CHANGE MASTER CODE ICON

4. Enter the master code (85) using the keypad.

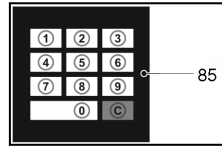

85. KEYPAD

The master code that was entered appears in the display unit (84) as filled in circles.

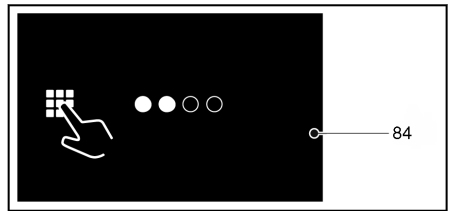

84. DISPLAY UNIT

5. Press the button under the "Delete" icon (89).



89. DELETE ICON

The master code is deleted.

6. Enter the new master code (85) using the keypad.

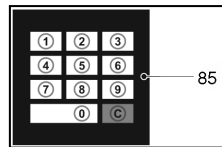

85. KEYPAD

**NOTE:** The new master code must be distinct from existing access codes.

- Press the button under the "Confirm" icon (90).

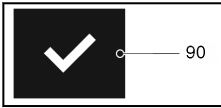

90. CONFIRM ICON

The new master code is displayed.

**NOTE:** If the new master code was entered incorrectly, delete the master code and add a new master code.

- To return to the main menu, press the button under the "Back" icon (91).

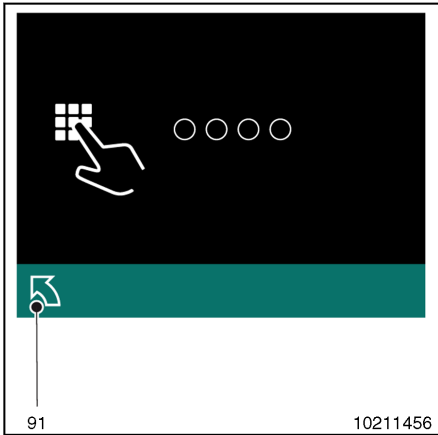

91. BACK ICON

The master code is changed.

2.2.5.4 ADDING A NEW ACCESS CODE

- Switch forklift truck on.
- Press the button under the "Setting" icon (87).

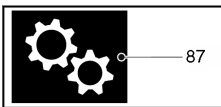

87. SETTING ICON

- Press the button under the "Edit access code" icon (92).

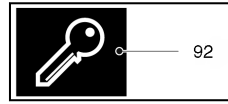

92. EDIT ACCESS CODE ICON

The master code is queried.

- Enter the master code (85) using the keypad.

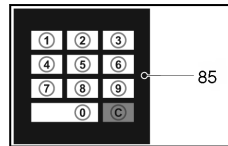

85. KEYPAD

All access codes appear in the display unit (84).

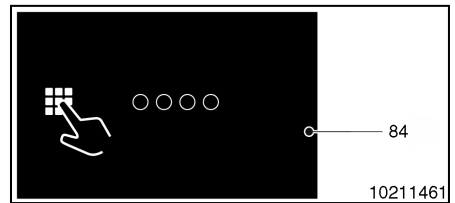

84. DISPLAY UNIT



5. Press the button under the "Add" icon (93).

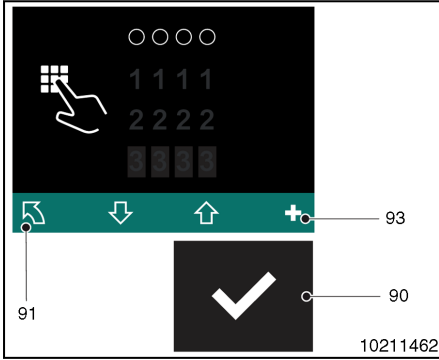

90. CONFIRM ICON

91. BACK ICON

93. ADD ICON

6. Enter the new access code (85) using the keypad.

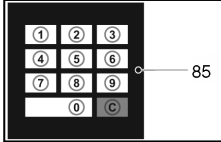

85. KEYPAD

**NOTE:** The new access code must be distinct from existing access codes.

7. Press the button under the "Confirm" icon (90).

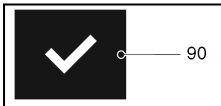

90. CONFIRM ICON

The new access code appears in the display unit (84).

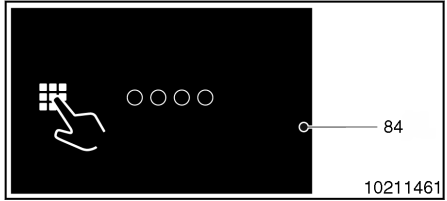

84. DISPLAY UNIT

**NOTE:** If the new access code was entered incorrectly, delete the access code see **Deleting an Access Code** and add a new access code.

8. To return to the main menu, press the button under the "Back" icon (91).

A new access code was added.

### 2.2.5.5 DELETING AN ACCESS CODE

1. Switch forklift truck on.
2. Press the button under the "Setting" icon (87).

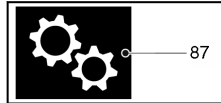

87. SETTING ICON

3. Press the button under the "Edit access code" icon (92).



92. EDIT ACCESS CODE ICON

The master code is queried.

4. Enter the master code (85) using the keypad.

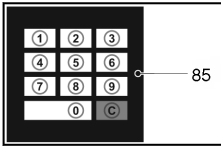

85. KEYPAD

All access codes appear in the display unit (84).

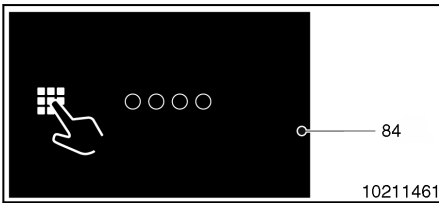

84. DISPLAY UNIT

5. Select the access code you want to delete with the button under the "Selection down" icon (94).

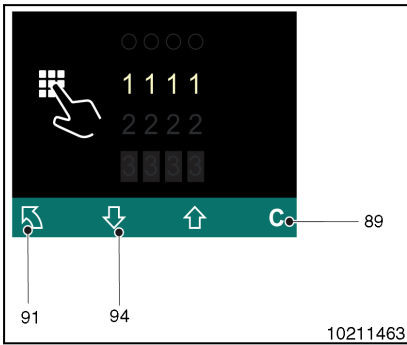

89. DELETE ICON

91. BACK ICON

94. SELECT DOWN ICON

6. Press the button under the "Delete" icon (89).

The access code was deleted.

7. To return to the main menu, press the button under the "Back" icon (91).

2.2.6 OPERATION OF THE DISPLAY UNIT

2.2.6.1 TURNING ON THE FORKLIFT TRUCK WITH AN ACCESS CODE

1. Release the EMERGENCY STOP switch, see **Emergency Stop**.
2. Enter the access code using the keys under the display (84).

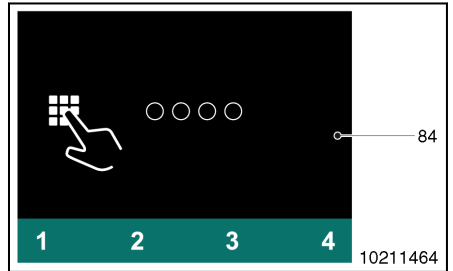

84. DISPLAY

The forklift truck is turned on.

2.2.6.2 TURNING OFF THE FORKLIFT TRUCK

1. Activate the button under the "Turn off" icon (86) in the display unit.
2. Press the EMERGENCY STOP switch, see **Emergency Stop**.



86. TURN OFF ICON

The forklift truck is turned off.

2.2.6.3 CHANGING THE MASTER CODE

1. Switch forklift truck on.

2. Press the button under the "Setting" icon (87).

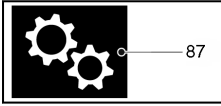

87. SETTING ICON

3. Press the button under the "Change master code" icon (88).

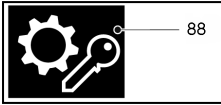

88. CHANGE MASTER CODE ICON

4. Enter the master code using the buttons under the display unit (84).

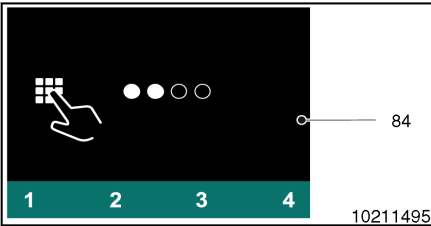

1. DISPLAY UNIT

The master code that was entered appears as filled in circles in the display.

5. Press the button under the "Delete" icon (89).

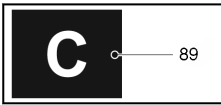

89. DELETE ICON

The master code is deleted.

6. Enter the new master code using the buttons under the display unit (84).

**NOTE:** The new master code must be distinct from existing access codes.

7. Press the button under the "Confirm" icon (90).

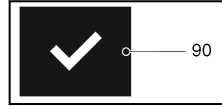

90. CONFIRM ICON

The new master code is displayed.

**NOTE:** If the new master code was entered incorrectly, delete the master code and add a new master code.

8. To return to the main menu, press the button under the "Back" icon (91).

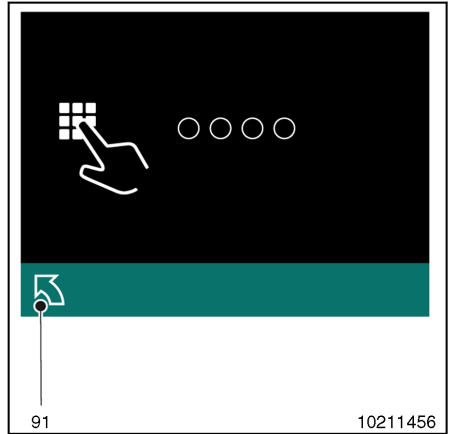

91. BACK ICON

The master code is changed.

2.2.6.4 ADDING A NEW ACCESS CODE

1. Switch forklift truck on.
2. Press the button under the "Setting" icon (87).

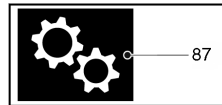

87. SETTING ICON

3. Press the button under the "Edit access code" icon (92).



## 92. EDIT ACCESS CODE ICON

The master code is queried.

4. Enter the master code using the buttons under the display unit (84).

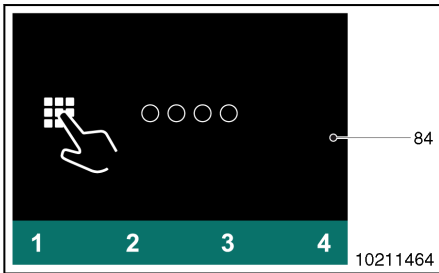

## 84. DISPLAY

All access codes are displayed.

5. Press the button under the "Add" icon (93).

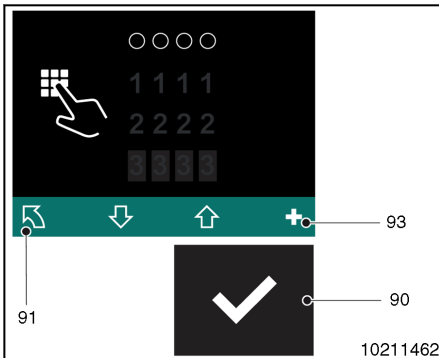

## 90. CONFIRM ICON

## 91. BACK ICON

## 93. ADD ICON

6. Enter the new access code using the buttons under the display unit (84).

**NOTE:** The new access code must be distinct from existing access codes.

7. Press the button under the "Confirm" icon (90).

The new access code is displayed.

**NOTE:** If the new access code was entered incorrectly, delete the access code see **Deleting an Access Code** and add a new access code.

8. To return to the main menu, press the button under the "Back" icon (91).

A new access code was added.

## 2.2.6.5 DELETING AN ACCESS CODE

1. Switch forklift truck on.
2. Press the button under the "Setting" icon (87).

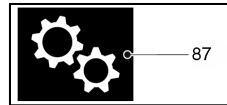

## 87. SETTING ICON

3. Press the button under the "Edit access code" icon (92).



## 92. EDIT ACCESS CODE ICON

The master code is queried.

4. Enter the master code using the buttons under the display unit (84).

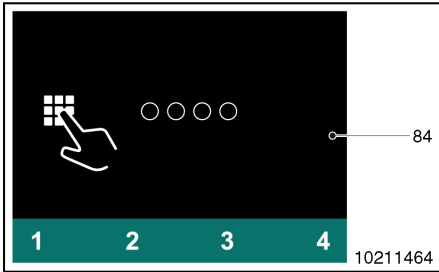

84. DISPLAY

All access codes are displayed.

5. Select the access code you want to delete with the button under the "Selection down" icon (94).

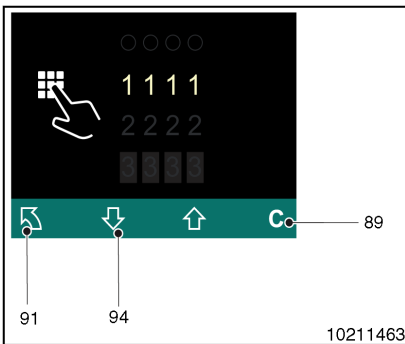

89. DELETE ICON

91. BACK ICON

94. SELECT DOWN ICON

6. Press the button under the "Delete" icon (89).

The access code was deleted.

7. To return to the main menu, press the button under the "Back" icon (91).

## 2.3 FUNCTIONALITY OF OPERATOR PRESENCE SYSTEM

### 2.3.1 PREVENTING OPERATOR'S ABSENCE

Be sure to operate the forklift truck and system correctly. Also, be sure to properly maintain, as well as operate, the system at all times.

This function prevents the forklift truck from traveling or lifting without the operator pressing the operator presence pedal and traction pedal. For details, see the tables below.

### 2.3.2 MAST OPERATION

When the operator raises their foot from the operator presence pedal, the mast will not lift, lower, or tilt even if the multi-function control handle is operated. To activate the mast functions, press the operator presence pedal.

#### Mast Function

Key Switch	Traction Pedal	Operator Presence Pedal	Fork Lift	Fork Tilt
ON	Not Pressed	Pressed	Active	Active
ON	Pressed	Not Pressed	Not Active	Not Active

#### WARNING

- Check the function of the operator presence system at the daily (prestart) inspection.
- Lower the load completely to the ground, apply the parking brake, and turn the key switch to the OFF position.
- The parking brake is not automatically applied.

### 2.3.3 TRAVEL OPERATION

When the operator raises their foot from the traction pedal, the system cuts power to the traction motors.

To activate the traction motors and start traveling, press the operator presence pedal and the traction pedal simultaneously.

Travel Function

Key Switch	Traction Pedal	Operator Presence Pedal	Travel
ON	Pressed	Not Pressed	Not Active
ON	Pressed	Pressed	Active
ON	Not Pressed	Pressed	Not Active

**WARNING**

- Check the function of the operator presence system at the daily (prestart) inspection.
- Lower the load completely to the ground, apply the parking brake, and turn the key switch to the OFF position.
- The parking brake is not automatically applied.

**2.4 CONTROLLED ROLL BACK FUNCTION**

This function prevents hazardous descending of the forklift truck on a grade. The controlled roll back is activated when the multi-function control handle is shifted into the neutral position or the traction pedal is slightly released on a grade. The descending speed changes with the steepness of grade and the weight of the load.

**NOTE:** This function is activated only in the output torque range of the traction motor. If the forklift truck can be decelerated until it stops in the output torque range, the electromagnetic brake will also be activated when the forklift truck stops.

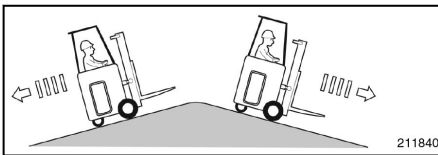

Forklift truck descends slowly when traction lever is shifted into neutral position or traction pedal is slightly released on a grade.

**2.5 BATTERY DISCONNECT**

**DANGER**

This forklift truck contains high voltage. Disconnect the battery before servicing.



If forklift truck is to be left unattended for an extended period of time, such as overnight, disconnect battery. NEVER service a forklift truck while battery is connected.

**2.6 FORK PINS**

**WARNING**

When adjusting the fork spread, be careful not to pinch your hand between forks and lift bracket.

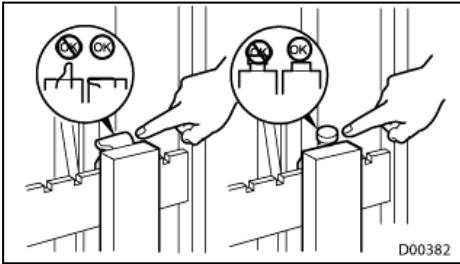

For load stability, adjust the forks as wide as possible.

To adjust the fork spread pull up and turn the pins to a 90-degree angle. Spread the forks to fit the load.

**CAUTION**

After adjusting the fork spread, restore the pins to the original position to lock the forks. Position each fork the same distance from the center of the backrest.

**2.7 REPLACING THE FORKS ON A FORKLIFT TRUCK**

Remove a fork from the lift bracket to replace it or to access other parts of the forklift truck for maintenance.

**WARNING**

DO NOT try to install or remove a fork without a lifting device. Each fork could weigh in excess of 45 kg (100 lb.).

**How to remove forks**

- (1) Slide the forks, one at a time, to the installation/removal recess on the bottom center of lift bracket bar.
- (2) Tilt the lift bracket FORWARD, then lower it until the fork hook disengages the forks from the lift bracket.
- (3) Use a lifting device to move the forks away from the forklift truck.

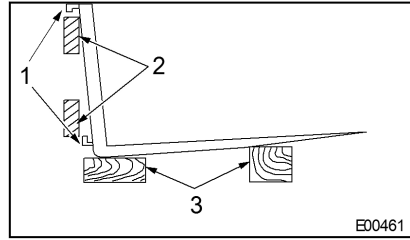

1. FORK HOOK
2. CARRIAGE BARS
3. WOOD BLOCKS

**How to install forks**

- (1) Position the forks side-by-side on the floor in a location where they can be approached from the rear by the forklift truck.
- (2) Slowly drive the forklift truck, with the lift bracket fully lowered and fully tilted FORWARD, to a point just to the rear of the forks.
- (3) Carefully slide the forks, one at a time, onto the lift bracket so the top hook of the fork is placed above the top carriage bar.
- (4) Raise the lift bracket to engage the top hooks allowing the bottom hooks to pass through the installation/ removal recess.
- (5) Carefully slide each fork on the carriage bar so both the upper and lower hooks engage the lift bracket.
- (6) Lock the forks in place by engaging the fork lock pins.

**2.8 SAFETY EQUIPMENT**

- Operator presence pedal
- Traction pedal
- Overhead guard
- Load Backrest extension
- Horn
- Warning decals

To reduce the risk of personal injury or death to you or those around you, DO NOT use a forklift truck without safety equipment in proper operating order.

## **2.9 ADDITIONAL WARNING DEVICES**

- Electronic back up smart alarm (optional)
- Alarm, travel, forward and reverse (optional)
- Alarm, travel, reverse (optional)
- Strobe (optional)
- Lights: mast mounted (optional)
- Rear spot light (optional)



## Chapter 3 How to Avoid a Tipover / How to Survive One

### 3.1 KNOW WHAT FORKLIFT TRUCK STABILITY IS

#### 3.1.1.1 PRINCIPLE OF BALANCE

Forklift truck design is based on the balance of two weights on opposite side of a fulcrum. In the case of the forklift truck, the balance point is the drive tires of the vehicle. Because the forklift truck and its weight are fixed, when you increase the load distance from the balance point or increase the weight of the load, you will decrease the capacity rating of the vehicle. The load on the forks must be balanced by the weight of the forklift truck and the battery. The location of center of gravity of both the forklift truck and the load is also a factor. This basic principle is used for picking up a load. The ability of the forklift truck to handle a load is discussed in terms of center of gravity and both forward and sideways stability.

#### 3.1.1.2 CENTER OF GRAVITY

Center of Gravity (CG) is defined as the point of an object where its weight is evenly distributed. If the object is uniform, its geometric center will be the same as its CG. If it is not uniform, the CG could be a point on either side of the geometric center. When the forklift truck picks up a load, the forklift truck and load have a new, combined CG.

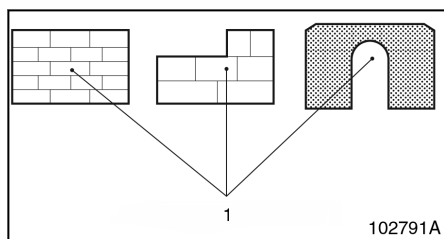

#### 1. CENTER OF GRAVITY

#### 3.1.1.3 STABILITY AND CENTER OF GRAVITY

The stability of the forklift truck is determined by the location of its CG, or if the forklift truck is loaded, the combined CG. The forklift truck has moving parts and, therefore, has a CG that moves. The CG moves up and down as the mast moves up and

down. The CG and, therefore, the stability of the loaded forklift truck, is affected by several factors such as:

- the size, weight, shape and position of the load
- the height to which the load is lifted
- dynamic forces created when the forklift truck is accelerated, braked, or turned
- condition and grade of surfaces on which the forklift truck is operated.

#### 3.1.1.4 FORKLIFT TRUCK STABILITY BASE

Stability is a measure of the forklift truck's resistance to overturning. For the forklift truck to be stable, the CG must stay within the area of the forklift truck stability base—a triangular area between the drive tires and the steer tires. If the CG moves outside of the line on either side of the stability base, the forklift truck will tip to the side. When lift height is added a stability pyramid is formed—a triangular area between the top of the mast, down to the drive tires and steer tires.

#### 3.1.1.5 CAPACITY (WEIGHT AND LOAD CENTER)

The capacity of the forklift truck is shown on the capacity plate. It is determined by the weight and load center. The load center is determined by the location of the CG of the load.

The load center shown on the capacity plate is the horizontal distance from the front face of the forks, or the load face of an attachment, to the CG in the load. The location of the CG of the vertical direction is the same as the horizontal dimension.

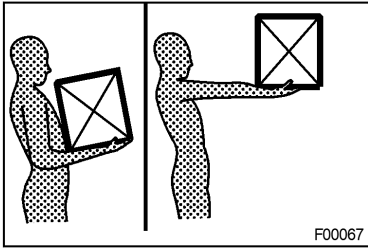

F00067

Keep in mind that, unless otherwise indicated, the capacity shown on the capacity plate is for a standard forklift truck with standard lift bracket, tires authorized by the manufacturer, forks and mast, and having no special-purpose attachment. In addition, the capacity presumes the load center is no further from the top of the forks than it is from the face of the lift bracket.

If these conditions do not exist, the operator may have to reduce the safe operating load because the forklift truck stability may be reduced. The forklift truck should not be operated if its capacity plate does not indicate capacity.

**3.1.1.6 CAPACITY NAME PLATE**

<b>WARNING</b>		IMPROPER OPERATION OR MAINTENANCE COULD RESULT IN INJURY OR DEATH	
MODEL	<input type="text"/>	SERIAL NO	<input type="text"/>
RATED CAPACITY	<input type="text"/>	LOAD CENTER DISTANCE	<input type="text"/>
NET WEIGHT EXCL. BATTERY +/- 5%	<input type="text"/>	ATTACHMENT	<input type="text"/>
BATTERY VOLTAGE	<input type="text"/>	MAX BATTERY CAPACITY	<input type="text"/>
BATTERY HEIGHT MIN/MAX	<input type="text"/>	HOUR RATE	<input type="text"/>
MANUFACTURER	<input type="text"/>	BATTERY ID	<input type="text"/>
		BATTERY WEIGHT MAXIMUM	<input type="text"/>

102114103

The capacity name plate shown is for a 1.5 ton model forklift truck whose capacity is 794 Kg (1,750 lb.) with a 4785 mm (188 in.) mast installed. The chart specifies this forklift truck can lift up to 794 Kg (1,750 lb.) if the load center is not more than 600 mm (24 in.) forward from the face of the backrest and 600 mm (24 in.) measured vertically from the top of the forks. Before attempting to pick up a load, make sure that its weight is within the capacity of the forklift truck at the load center involved. The capacity is also affected by the

weight of the battery. The battery must be within the minimum and maximum weights.

**NOTE:** Capacity name plate will differ depending on the model and options.

**NOTE:** If the load is not uniform, the heaviest portion should be placed closer to the lift bracket and centered on the forks.

**3.1.1.7 ATTACHMENTS**

**WARNING**

Make sure the capacity name plate is correct if an attachment has been installed.

If an attachment is installed on the forklift truck, make sure the attachment operating instructions are available and understood before operating the attachment.

**DANGER**

In the event of an imminent tip-over step off and away from the forklift truck as quickly as possible.

Exit from a stand-up type forklift truck with rear entry access by stepping backward if a tipover occurs.

**CAUTION**

- Capacity name plates originally affixed to forklift trucks sold by the manufacturer shall not be removed, altered or replaced without prior written approval from MCFA.
- The manufacturer assumes no responsibility for forklift trucks placed in service without a valid manufacturer capacity name plate.
- If it is necessary to change your specifications, contact your dealer.

**⚠ WARNING**

When the forklift truck is equipped with a high mast, the capacity is reduced based on lift heights. Before attempting to lift any load, make sure the weight and load center combination is within the capacity of the high mast as shown on its capacity name plate.

When the forklift truck is equipped with any special-purpose attachment, the capacity is varied by the weight of the attachment and the front overhang (horizontal distance from the center of the front axle to the vertical faces of the forks). Before attempting to lift any load, make sure the weight and load center combination is within the capacity of the attachment as shown on its capacity name plate.

**3.2 DO'S AND DON'T'S TO AVOID TIP OVER**

**⚠ WARNING**

- In case of tip over, jump clear of the forklift truck.
- Exit from a forklift truck with rear entry access by stepping backward.

**⚠ WARNING**

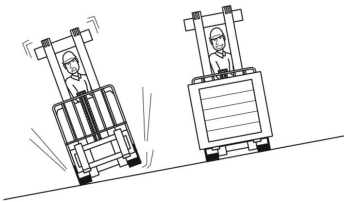

11 2

**Be aware of the stability of an empty forklift truck!**

An empty forklift truck could tip over more easily than a loaded one.

In the event of an imminent tip over step off and away from the forklift truck as quickly as possible.

**⚠ WARNING**

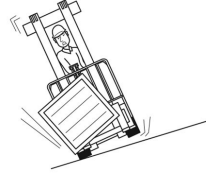

11\_5

**DO NOT turn on a ramp or grade!**

Turning on a ramp or grade could cause a forklift truck, loaded or unloaded, to tip over.

In the event of an imminent tip over step off and away from the forklift truck as quickly as possible.

**⚠ WARNING**

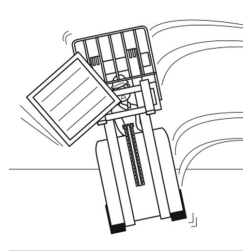

11\_3

**Always be alert for tip overs!**

Turning sharply with a raised load, even at a slow speed, could result in a tip over.

A forklift truck with a raised mast will tip over more easily than a forklift truck with a lowered mast because the stability of the forklift truck worsens.

In the event of an imminent tip over step off and away from the forklift truck as quickly as possible.

**⚠ WARNING**

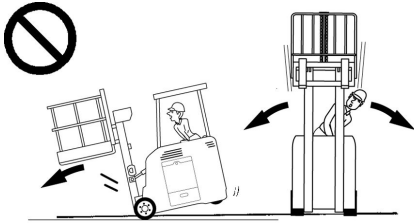

D00078V

**DO NOT travel with forks higher than 15 to 20 cm (5.91 to 7.87 in.) above the ground!**  
The CG moves up increasing the possibility of a tip over.

In the event of an imminent tip over step off and away from the forklift truck as quickly as possible.

**⚠ WARNING**

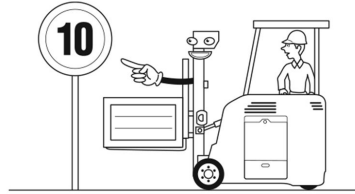

15\_3

**Obey all traffic regulations and warning signs, including authorized plant speed limits!**

Drive carefully, observe traffic rules and be in full control of the forklift truck at all times.

A safe distance must be maintained by staying approximately three forklift truck lengths from the forklift truck ahead, and the forklift truck must be kept under control at all times. Use special care when traveling without a load as the risk of tip over is greater.

**⚠ WARNING**

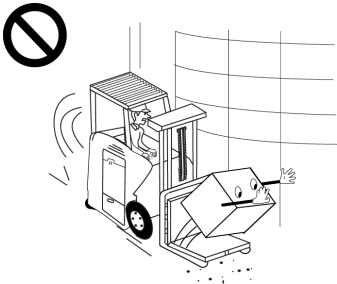

D00073V

**Avoid fast starts, turns, and sudden stops!**  
These movements could cause the forklift truck to tip over.

In the event of an imminent tip over step off and away from the forklift truck as quickly as possible.

**⚠ WARNING**



F00080V

**DO NOT raise FORWARD titled loads!**  
This could also cause the forklift truck to tip over.

In the event of an imminent tip over step off and away from the forklift truck as quickly as possible.

**⚠ WARNING**

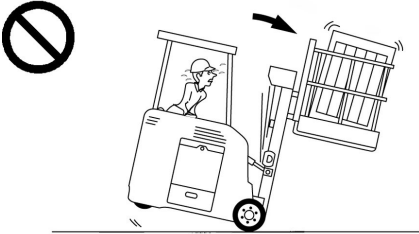

D00079V

**DO NOT tilt elevated loads FORWARD!**  
DO NOT tilt elevated loads forward except when the load is in a deposit position over a rack or stack. This could cause the forklift truck to tip over.

In the event of an imminent tip over step off and away from the forklift truck as quickly as possible.

**⚠ WARNING**



J00040V

Avoid sudden stops. This could cause the load to fall off the forks or the forklift truck to tip over.

**⚠ WARNING**

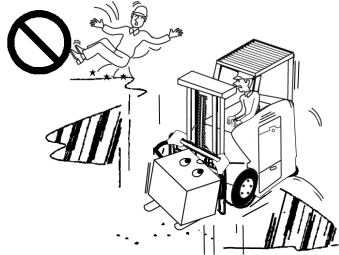

F00086V

**Slow down for wet and slippery surfaces!**

- Loose or slippery materials such as sand, gravel, ice, mud, etc., on your operating surfaces could cause a skid or tip over.
- Avoid these conditions or slow down.
- Keep your operating surfaces clean and dry at all times.
- Wet spots could cause a skid or tip over. You need a greater stopping distance on wet surfaces.
- Apply brakes earlier on slippery surfaces than on dry surfaces. DO NOT drive into a flooded area.

In the event of an imminent tip over step off and away from the forklift truck as quickly as possible.

**⚠ WARNING**

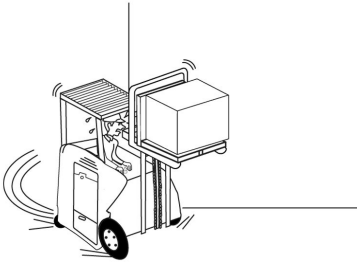

J00100V

**Always be alert for tip overs!**

Turning sharply with a raised load, even at a slow speed, may result in a tip over. Realize that the overhead guard is not designed to provide total protection in the event of a tip over.

In the event of an imminent tip over step off and away from the forklift truck as quickly as possible.

**⚠ WARNING**

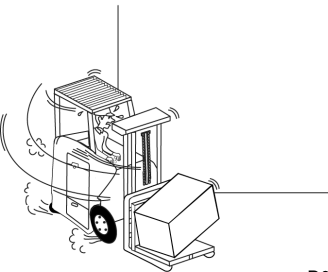

D00190V

**DO NOT speed when making turns!**

Drive slowly when making turns to avoid a tip over.

In the event of an imminent tip over step off and away from the forklift truck as quickly as possible.

**⚠ WARNING**

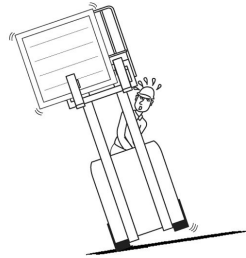

D00076V

**DO NOT pick up or place a load on grades!**

DO NOT attempt to pick up or place a load on grades that could affect the forklift truck's stability.

In the event of an imminent tip over step off and away from the forklift truck as quickly as possible.

**⚠ WARNING**

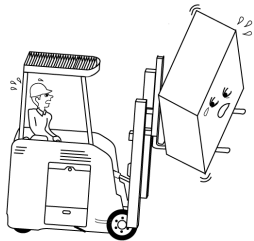

D00077V

**Avoid off-center loading!** Only stable or safely arranged loads must be handled!

Keep the center of gravity low and avoid off-center loading. Off-center loads could cause tip over or falling loads.

Slowly operate the forklift truck when picking up or placing a long or wide load, or when turning with such a load.

In the event of an imminent tip over step off and away from the forklift truck as quickly as possible.

**⚠ WARNING**

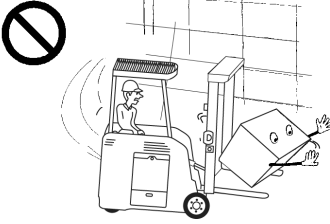

F00073V

**Avoid fast starts, turns, and sudden stops!**

These movements could cause the forklift truck to tip over.

In the event of an imminent tip over step off and away from the forklift truck as quickly as possible.

## Chapter 4 Operation

### 4.1 NEW FORKLIFT TRUCK BREAK-IN

Correct break-in is important for operation and long life of the forklift truck. Read these recommended procedures:

#### CAUTION

1. If the forklift truck cannot be put to work immediately, or the operation is light and slow, break in the forklift truck under a simulated working condition.
2. Change oils and relubricate at shorter intervals than the normal recommended intervals when in dirty environments.
3. Hydraulic tank return line filter should be replaced after the first fifty (50) hours of operation and at the recommended intervals thereafter.
4. Carefully check on and around the forklift truck for loose bolts and nuts. Retighten them.

### 4.2 BEFORE STARTING OPERATIONS

#### WARNING



100607A

BE SURE to perform daily PRE-START INSPECTION.

#### WARNING

BE SURE TO READ the SAFETY RULES FOR FORKLIFT TRUCK OPERATORS for your safety and the safety of fellow workers.

### 4.3 BEFORE MOVING THE FORKLIFT TRUCK

#### 4.3.1 BEFORE MOVING THE FORKLIFT TRUCK - OVERVIEW

Before operating your forklift truck, make sure you read and understand all warnings, including the following:

#### WARNING

1. Operate this forklift truck slowly and in an open area until you are thoroughly familiar with all the controls.
2. Operate this forklift truck only from the designated operating position. Never place any part of your body between the mast upright or outside the operator compartment while operating this forklift truck. (The operator compartment is that space in which the operator stands to operate the forklift truck.)
3. Avoid sudden stops or changes in direction which could cause the vehicle to tip or the load to shift.

#### 4.3.2 START-UP PROCEDURE

1. Make sure battery is charged.
2. Make sure both battery gates are in place
3. Make sure battery cannot move more than ½ inch (13mm) in any horizontal direction.
4. Connect battery to forklift truck.

**NOTE:** Battery cable should not be routed outside the profile of the truck.

5. Turn the key switch clockwise to the ON position or enter the code in the key pad (optional). Start PIN 2580. SelfTest will start and readings will be shown on the display. Do not activate any control elements, such as the operator presence pedal during SelfTest.
6. After the SelfTest is complete, step into the operator compartment. Depress the operator presence pedal with right foot and the traction pedal with left foot.



SelfTest can be identified by the contactor clicking. If faults are found during a SelfTest, a fault message is shown on the operator display. An alarm is indicated on the operator display. Do not operate the forklift truck until the problem is corrected.

7. Make sure forks are lowered completely.
8. Check the operation of the EPO button as follows:
  - a. Pull the EPO button OUT while twisting it clockwise.
  - b. Turn the key switch clockwise to ON.
  - c. Push the EPO button IN. This should completely shut down the forklift truck. You should not be able to drive the forklift truck, lift the forks, tilt the carriage, etc.
  - d. Turn the EPO button clockwise and pull up to release.
9. Release parking brake by pressing the button directly below the parking brake icon on the console display screen.
10. Use your left hand to steer the forklift truck and your right hand to control travel, lift and auxiliary functions. See [Forklift Truck Operation, Page 4-3](#)
11. Test the steering.
12. Test the brakes.
13. Test the parking brake.
14. Test the horn button.
15. Check the operator presence pedal for functionality.
16. Test the drive function.
17. Check the lift function.

The forklift truck is operational.

**NOTE:** The forklift truck can be driven either forks first or tractor first. If you are not sure which way the forklift truck will move, slowly move the multi-function control handle forward or reverse to determine which way the forklift truck is moving.

## 4.4 ADJUSTABLE COMFORT OPERATOR PLATFORM

The Comfort operator platform has adjustable springs to increase comfort when driving on uneven surfaces. The human vibrations that affect the operator during travel are significantly reduced with a suitable setting. Above the operator platform, up to six gas pressure springs can be switched with a lever to adjust to the operator's weight (79).

**NOTE:** The gas pressure springs 5 and 6 have double the pressure force.

Adjustment recommendation for adjustable Comfort operator platform

Operator weight	Switched Number of Gas Springs	
	Recommendation	Recommendation
115 lb (52 kg)	0	0
137 lb (62 kg)	0	0 to 1
165 lb (75 kg)	1	0 to 2
192 lb (87 kg)	2	1 to 3
220 lb (100 kg)	3	2 to 4
276 lb (125 kg)	4	3 to 5
331 lb (150 kg)	5	3 to 5

1. Unload platform.
2. Optionally, up to six gas springs can be switched on by moving the lever (79) upward or off by moving the lever (79) downward.

**NOTE:** Selecting too few gas pressure springs or too little spring power can cause touchdown of the sprung platform. Selecting too many gas pressure springs or too much spring power can cause only slight or no reduction during travel of human vibrations affecting the operator.

3. Comfort operator platform is adjusted.

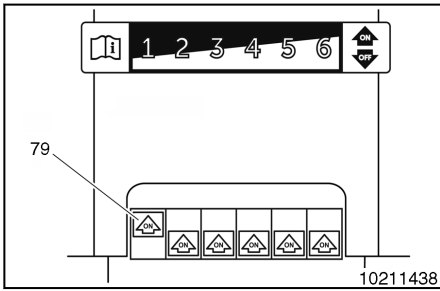

79. LEVER

### 4.5 ADJUSTING THE ARM REST

1. Stand in the forklift truck in the operating position.
2. Operate the rocker switch (1) to obtain the desired height of the arm rest.

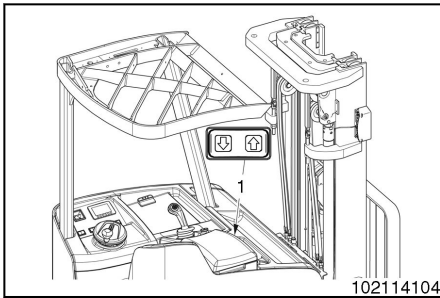

1. ROCKER SWITCH

### 4.6 FORKLIFT TRUCK OPERATION

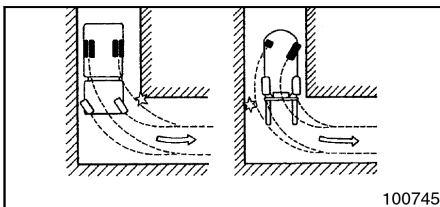

100745

A forklift truck is different from most other vehicles in that it is steered by the rear wheel. This causes an exaggerated tail swing.

Drive slowly when making turns in close quarters. Start the turn as close to the inside corner as the tail swing will permit.

#### WARNING

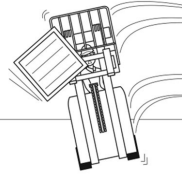

11\_3A

Turning with the forks elevated, with or without a load, could cause a tipover.

In the event of an imminent tip-over step off and away from the forklift truck as quickly as possible.

#### WARNING

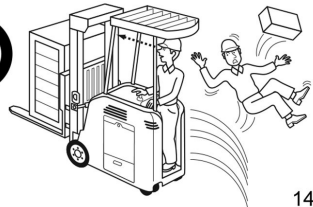

14\_6A

Be aware of tail swing distance. Be sure the tail swing area is clear, before turning, to avoid injury to pedestrians.

#### WARNING



46\_3

Use extreme care when turning without a load. Excessive speed with abrupt turns or uneven surfaces may cause the forklift truck to tip when empty as well as loaded.

In the event of an imminent tip-over step off and away from the forklift truck as quickly as possible.

**4.7 CHANGING SPEED**

The forklift truck will change its speed to match the position of the multi-function control handle. The farther the multi-function control handle is moved from the neutral position, the faster the forklift truck travels. This is true when accelerating and

decelerating. This means the forklift truck is not free to “coast” long distances when the travel control is returned to the neutral position.

**4.8 TRAVEL DIRECTION**

**4.8.1 TRAVEL DIRECTION DEFINITION**

The following specifications are given for defining the travel direction:

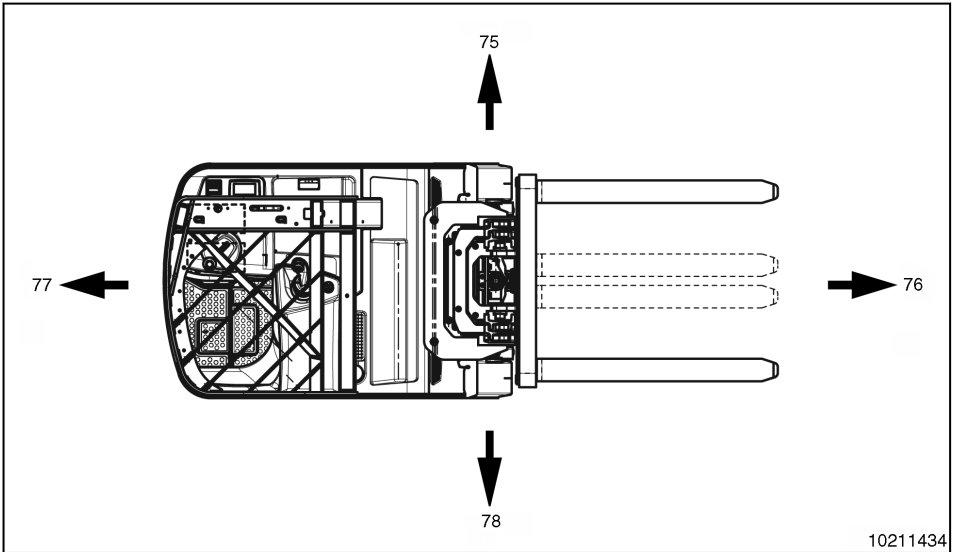

10211434

Item	Travel Direction
75	Forks first left
77	Drive direction
76	Load direction
78	Forks first right

### 4.8.2 PARKING BRAKE WARNING ICON

The parking brake is operated from the control panel. Push the button directly below the parking brake icon to set or release the parking brake.



When set, the  will be red.



When released, the  will be green.

### 4.9 CHANGING DIRECTIONS

- Move the multi-function control handle through neutral to the direction opposite of your current travel. This action is called “plugging.” The farther you move the multi-function control handle, the faster you slow down.
- The forklift truck slows, stops, and starts moving in the opposite direction. Plugging is the recommended method of slowing travel speed and changing direction during operational maneuvers.

### 4.10 BRAKING

The forklift truck’s braking response depends largely on the travel surface conditions. The operator should adapt his or her driving style accordingly.

The forklift truck can be stopped in three ways:

- With the traction pedal
- With the coasting brake (multi-function control handle)
- With the reverse brake (multi-function control handle)

#### WARNING

##### **Risk of accidents due to individually set parameters**

If the forklift truck is driven by several operators (for example in multi-shift operation), be aware of modified braking and driving response due to individually set parameters!

**NOTE:** Check the response of the forklift truck when starting up.

#### WARNING

##### **Risk of accidents**

The braking response of the forklift truck depends largely on the travel route conditions.

**NOTE:** The operator must be aware of travel route conditions and take them into account when braking. Brake the forklift truck with care to prevent the load from slipping. When driving with a load, allow for longer braking distances. In case of danger, brake only with the service brake.

4.10.1.1 BRAKING WITH THE SERVICE BRAKE

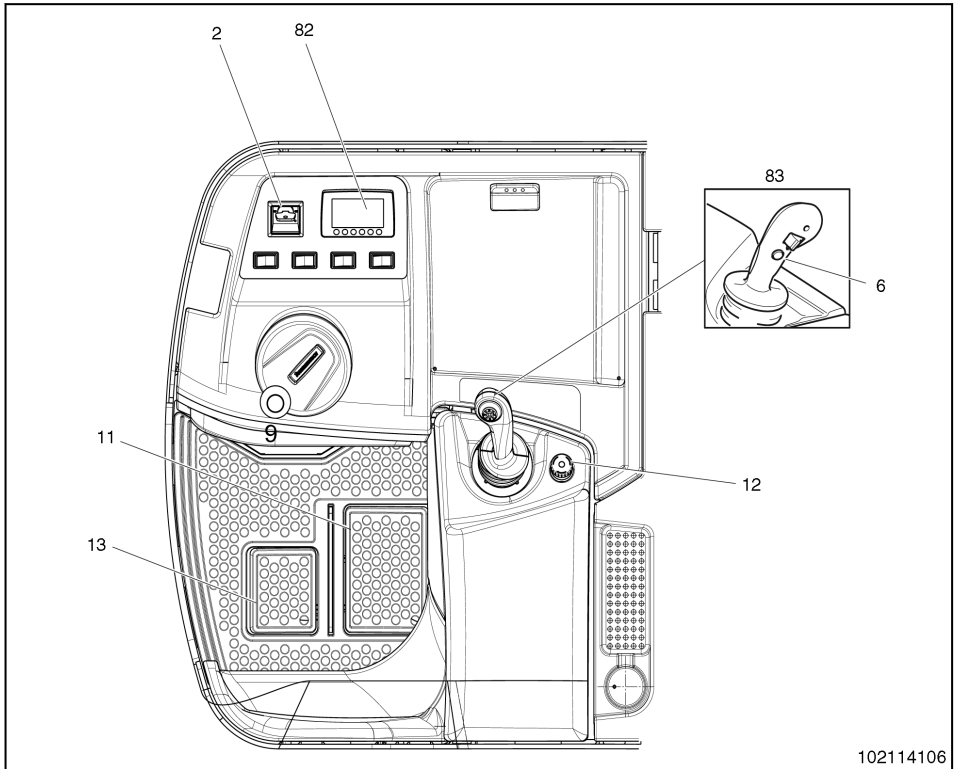

102114106

1. Take foot slightly off the traction pedal (13).  
The forklift truck decelerates slightly.
2. Lift foot off the traction pedal (13).  
The forklift truck decelerates.

### 4.10.1.2 BRAKING WITH THE COASTING BRAKE

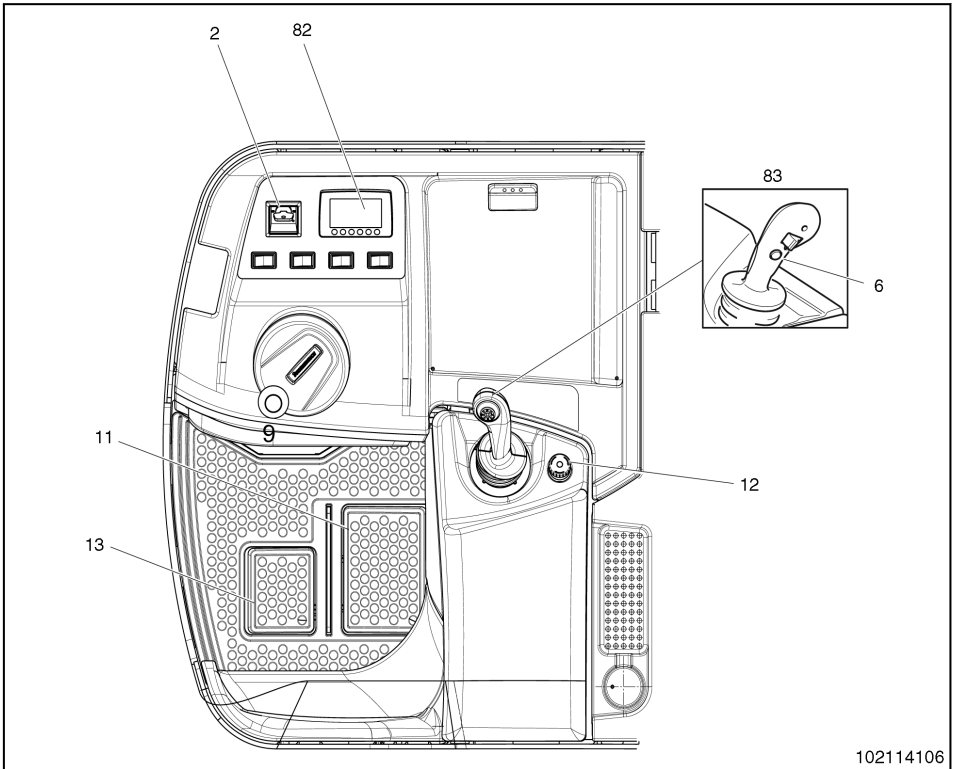

102114106

1. Release the multi-function control handle to the neutral position (83). The forklift truck decelerates.

4.10.1.3 BRAKING WITH THE REVERSE BRAKE

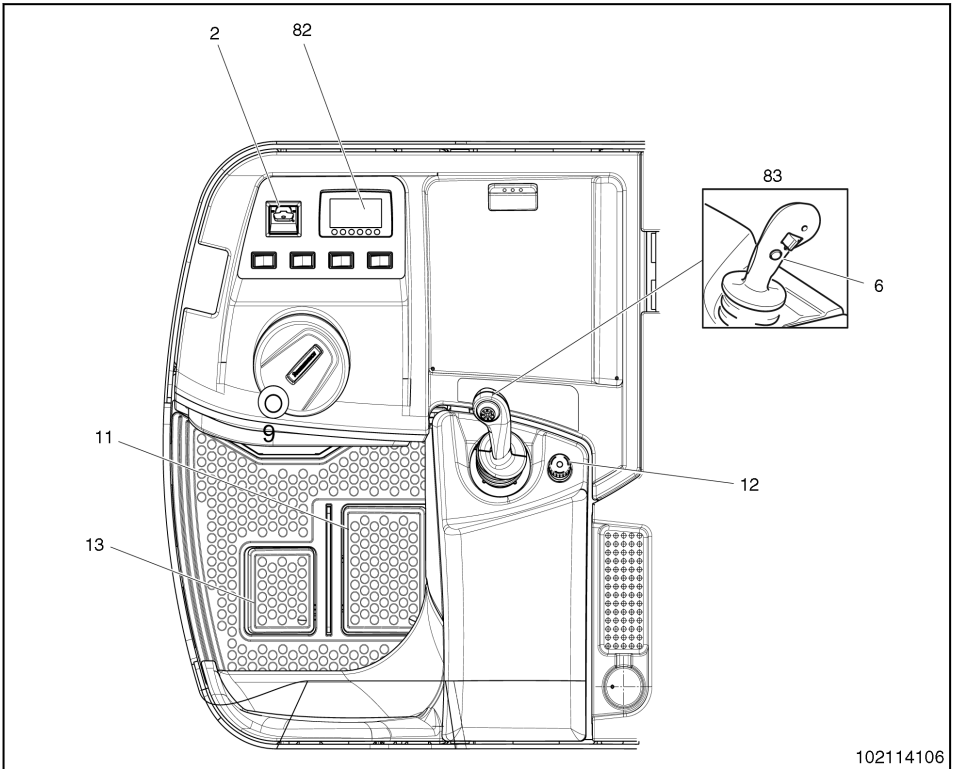

1. While traveling, switch the multi-function control handle (83) to the opposite travel direction.  
The forklift truck decelerates until it starts to move in the opposite travel direction.

- The forklift truck will slow down, come to a stop, and then start traveling in the opposite direction. The farther past neutral you move the multi-function control handle, the greater the plugging force.

4.11 PLUGGING

Plugging is the correct method for stopping the forklift truck. Plugging provides the means to bring the forklift truck to a smooth, controlled stop.

- Move the multi-function control handle through the neutral position in the direction opposite direction the forklift truck is traveling.

The brake which is engaged when lifting your foot off the operator presence pedal or traction pedal should only be used in emergency situations.

4.12 AT THE END OF EACH SHIFT

1. Park the forklift truck in a secure and authorized parking area.
2. Stop the forklift truck.
3. Lower the forks completely.
4. Turn the key switch OFF (O).

5. Push in the EPO (Emergency Power Off) button.
6. Remove the key from the key switch.
7. Disconnect the battery.
8. Check around forklift truck for leaking hydraulic fluid.

** WARNING**

Never park this forklift truck on a ramp or a slope.

**DO NOT** park this forklift truck in a cold storage area overnight.



## Chapter 5 Operating Techniques

### 5.1 STACKING METHODS

#### 5.1.1 STACKING LOADS DIFFERING IN SIZE

Be sure larger containers in a load are at the bottom of the stack and smaller ones at the top; or heavier containers at the bottom and lighter ones at the top.

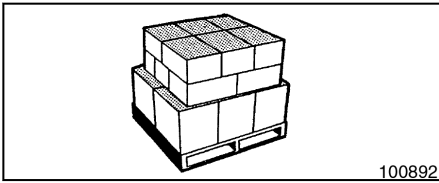

#### 5.1.2 STACKING SMALL IDENTICAL LOADS

As in brick laying, place layers of containers alternately so each container will stand astride parts of two or more containers in the layer below. This type of stack is more stable and less likely to fall down.

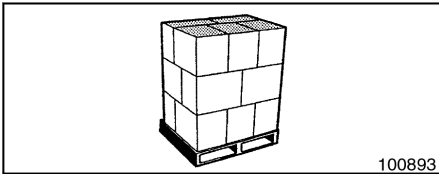

#### 5.1.3 STACKING LARGE IDENTICAL LOADS

Below is one of the most common patterns for stacking large identical containers. Better load stability is achieved by reversing the end-to-side direction on each succeeding layer.

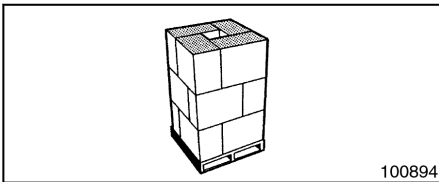

### 5.2 LIFTING THE LOAD

- (1) Move up to the load and stop the forklift truck 20 to 30 cm (8 to 12 in.) short of the load.
- (2) Make sure the forklift truck is square with the load and the forks are at the correct height.

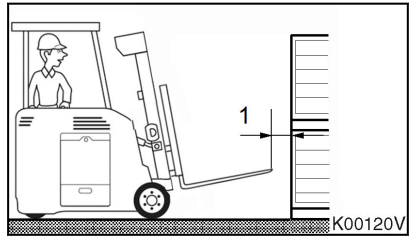

1. 20 TO 30 CM (8 TO 12 IN.)

#### **⚠ WARNING**

When you pick up loads that extend above the lift bracket extension height, band them together to reduce the risk of items from falling.

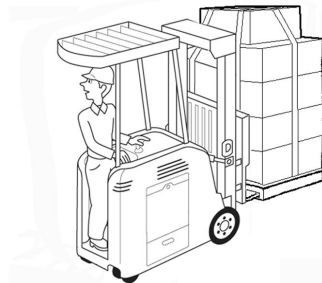

- (3) Tilt the mast FORWARD to the VERTICAL position, and make sure the forks are at the correct height.

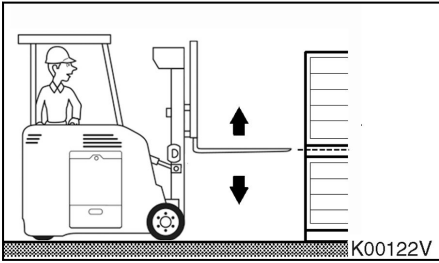

K00122V

**WARNING**

Only stable or safely arranged loads must be handled. **DO NOT** pick up an off-center load. Make sure the weight of the load is centered between the forks.

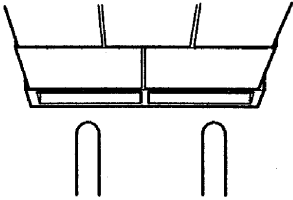

K00123

- (4) Push the multi-function control handle toward the forks to the FORWARD position and slowly move the forklift truck FORWARD.
- (5) Slide the forks into the pallet until they are fully under the load.

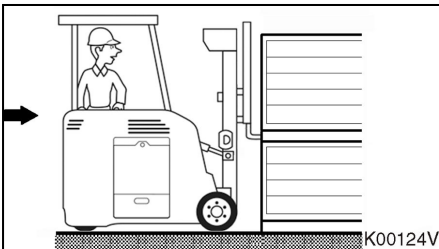

K00124V

**WARNING**

Avoid approaching the load at high speeds. Under all travel conditions, operate the forklift truck at a speed that will permit it to be brought to a stop in a safe manner.

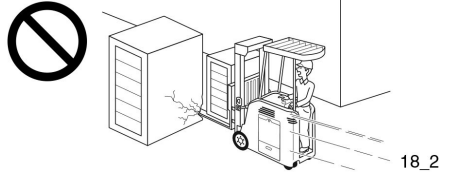

18\_2

- (6) Carefully lift the load about 10 cm (4 in.) off the stack. Slowly return the lift lever to the NEUTRAL position.

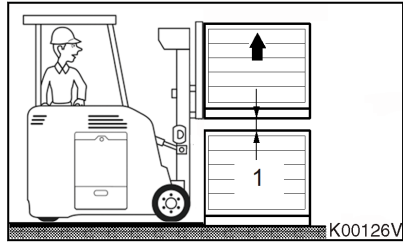

K00126V

1. 10 CM (4 IN.)

**⚠ WARNING**

**DO NOT mistake the direction and control levers!**

If you operate the steering wheel or multi-function control handle incorrectly, collision of the forklift truck with persons or objects could occur, or you could drop the load.

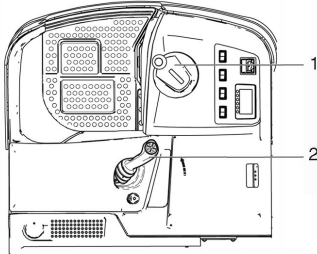

10211497

1. STEERING WHEEL
2. MULTI-FUNCTION CONTROL HANDLE

**5.3 TRAVELING WITH THE LOAD**

**⚠ WARNING**

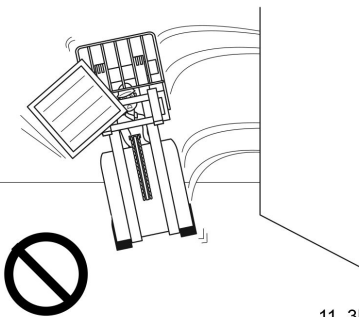

11\_3B

- NEVER travel with the lift bracket tilted forward or with the load in the elevated position. This could increase the possibility of the forklift truck tipping over.
- NEVER leave the forklift truck with the load in the elevated position.

1. Make sure the load is centered on the forks. Then tilt the carriage all the way back.
2. Before moving the load, look around for pedestrians, other vehicles, and obstacles.
3. Slowly move the forklift truck 20 to 30 cm (8 to 12 in.) away from the stack, then stop the forklift truck. Lower the load to a position 15 to 20 cm (6 to 8 in.) above the ground.
4. Look around to make sure your drive area is clear

**⚠ WARNING**

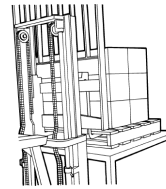

101525

Slack lift chains mean there is a rail or lift bracket hang-up. Raise the mast before you move.

When stacking:

1. Watch your lift chains.
2. If they go slack, stop, raise the load and lower it again.

**⚠ WARNING**

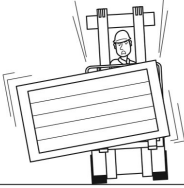

47\_1

Only stable or safely arranged loads must be handled!

Keep the center of gravity low and avoid off-center loading. Off-center loads could cause tipover or falling loads.

Slowly operate the forklift truck when picking up or placing a long or wide load, or when turning with such a load.

In the event of an imminent tip-over step off and away from the forklift truck as quickly as possible.

**⚠ WARNING**

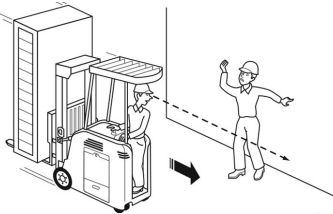

15\_2A

If the load blocks your view, or when you travel down a grade with the load, drive in reverse. Always look in the direction of travel.

**5.4 UNLOADING**

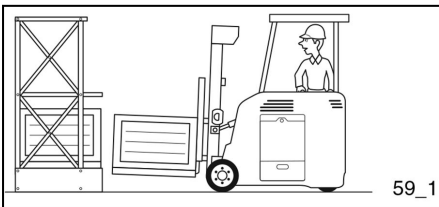

59\_1

1. Move the forklift truck slowly and stop 20 to 30 cm (8 to 12 in.) short of the rack or load. Make sure the forklift truck is square with the rack and load.

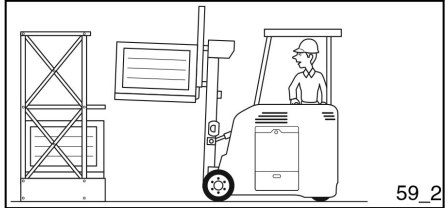

59\_2

2. Raise the load with enough height to clear the loading platform and be careful not to hit upper rack level. Level out the load with the tilt button on the multi-function control handle.

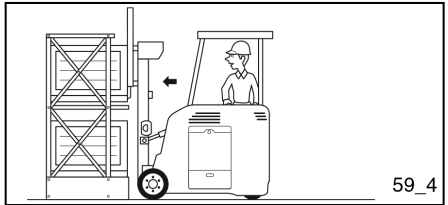

59\_4

3. Once you are clear, you may need to move the forklift truck forward to even up the load or reposition the load.

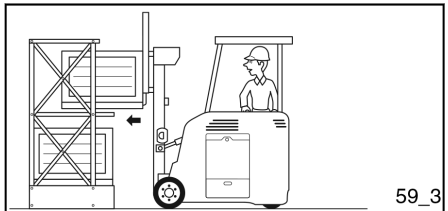

59\_3

4. Watch your drive tires and do not hit the rack.

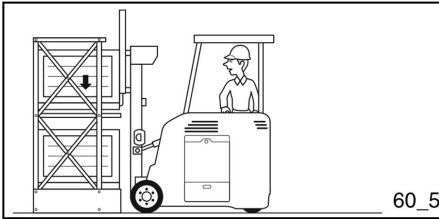

60\_5

5. Carefully lower the load onto the rack platform.  
Be careful not to drag the forks.

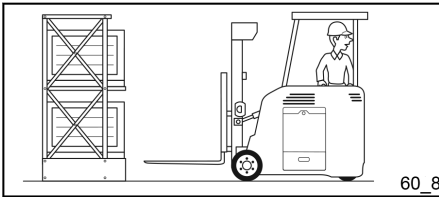

60\_8

6. Look behind and around the forklift truck and to see that it is safe to carefully back the forklift truck away from the rack.  
Proceed to your next load.

## 5.5 WORKING ON GRADES

### WARNING

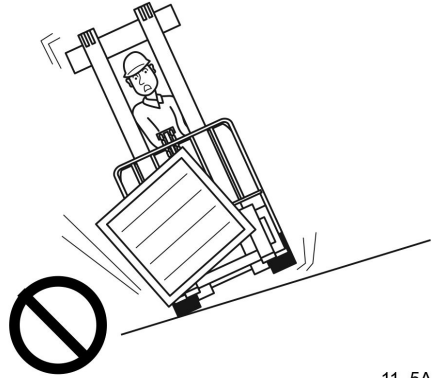

11\_5A

- NEVER elevate the mast when the forklift truck is on a ramp
- NEVER elevate a load with the forks tilted down.
- NEVER travel with the load elevated when the forklift truck is on a ramp.
- NEVER turn on a ramp.
- NEVER travel across a grade
- Always make sure the forklift truck is square with the ramp before ascending or descending.

## Chapter 6 Storing the Forklift Truck

### 6.1 END OF SHIFT STORAGE

#### WARNING

Perform a thorough walk-around inspection for any damage. Report all damage or faulty operation immediately. DO NOT operate a forklift truck that has a maintenance problem.

1. Park the forklift truck in an authorized area.
2. Check under the forklift truck for oil leaks.
3. Clean the forklift truck to keep it free of dirt and oil.  
This will make it easier to spot loose or defective parts.

#### CAUTION

Do not expose controller units to water. Take care not to sprinkle water over controller units when washing your machine.

#### WARNING

- NEVER splash water over the forklift truck.
- Use pressurized air or a vacuum cleaner to clean the forklift truck.

### 6.2 LONG-TERM STORAGE

If your forklift truck is to be put in storage for any length of time, take the following precautions for safety and to reduce the risk of deterioration of forklift truck components.

#### 6.2.1.1 HYDRAULIC SYSTEM

After positioning your forklift truck for storage, retract all the hydraulic cylinders to minimize rod exposure. This will reduce the risk of rusting of the sliding contact surfaces of the rods.

#### 6.2.1.2 BATTERY

- Fully charge the battery. Recharge it with an equalizing charge if the forklift truck is left standing for more than three days.
- Charge the battery with an equalizing charge at least once a month if the forklift truck is to be left standing for more than a month.

## Chapter 7 Transportation Hints

### 7.1 FORKLIFT TRUCK SHIPPING

1. Always block the trailer or rail cars wheels before loading the forklift truck.
2. Position the forklift truck on the truck bed or rail car.
3. Fully lower forks or attachment to the floor.
4. Place the multi-function control handle in the neutral position
5. Turn the key switch to the OFF position and remove the key.
6. Block the wheels and block in the truck to secure the forklift truck.

#### **CAUTION**

DO NOT turn steering wheel after the forklift truck has been secured. It may loosen the tie-downs.

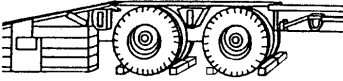

M00002

#### **WARNING**

Check travel route for overpass clearances. Make sure there is adequate clearance if the forklift truck being transported is equipped with a high mast or cab.

Remove ice, snow, or other slippery material from the shipping forklift truck and loading dock.

### 7.2 FORKLIFT TRUCK LIFTING AND TIEDOWN INFORMATION

Take the following safety precautions when lifting or tying down forklift trucks.

- Use proper rated cables and slings for lifting. Position the crane so the forklift truck is level when lifted.
- Spreader bar widths should be sufficient to prevent contact with the forklift truck.
- Use the tie-down locations provided for forklift truck tiedown.

#### **CAUTION**

Incorrect lifting or tie-downs could cause a load to shift and could cause injury and/or damage.

**NOTE:** Check the state and local laws governing weight, width, and length of a load. Contact your authorized dealer for shipping instructions for your forklift truck.

## Chapter 8 Special Situations

### 8.1 CARE IN COLD WEATHER

#### 8.1.1 BATTERY

- Maintain the specific gravity of electrolyte above 1.260 as corrected to 27°C (80°F).
- When you park your forklift truck overnight, leaving it outside a garage, remove the battery and keep it warm.
- The electrolyte of a fully charged battery will not freeze to -35°C (-31°F).
- Do not leave the forklift truck in a freezer overnight.

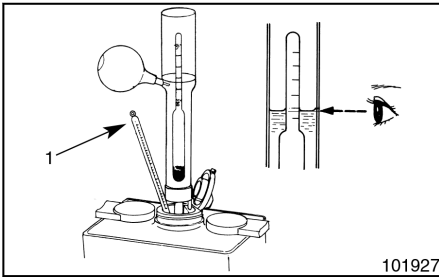

#### **CAUTION**

- After distilled water has been added to the battery, drive the forklift truck. This mixes the added water with the electrolyte and will reduce the risk of freezing and damaging the battery.
- DO NOT attempt to restore a battery's charge by pouring boiling water over it. This can break the battery case, resulting in acid contact with skin or eyes.

### 8.2 CARE IN HOT WEATHER

#### 8.2.1 HOT WEATHER BATTERY SERVICE

In hot dry weather, check the battery cells for proper electrolyte level more often than in cold weather. Add distilled water whenever the level is low.

- Use hydraulic and gear oil suitable for the ambient temperatures.

- For selection of hydraulic oil and gear oil, consult your Service Data chart for recommended oils or your authorized dealer.
- In addition, a lubrication chart is located inside the operator compartment door at the rear of the forklift truck.

### 8.3 COLD STORAGE SPECIFICATIONS

#### 8.3.1 DESCRIPTION OF THE ENVIRONMENT AND OPERATION OF THE FORKLIFT TRUCKS

Cold storage conditioning is required when a forklift truck operates in cold storages such as coolers or freezers. Condensation, especially when frozen, is a primary issue in this environment. Cold storage conditioning is also recommended when a forklift truck operates in a high humidity environment.

Cold storage applications are divided into two groups:

#### **COOLER (High Temperature Freezer Forklift Truck)**

Applies to forklift trucks operating in:

- Environments where ambient temperatures fluctuate from +20°F (-7°C) to +70°F (21°C).
- Continuous duty cycle in cooler or high temperature freezer.
- Applications where forklift trucks go in and out of freezers for short periods of time. A short period of time is defined as 5 minutes.
- Very wet environments

#### **FREEZER (Low Temperature Freezer Forklift Truck)**

Applies to forklift trucks operating in:

- An environment where temperatures fluctuate from +40°F (4°C) to -40°F (-40°C). This would be where the forklift truck operates between a cooler and low temperature freezer.
- A continuous temperature of -20°F (-29°C) for an entire shift.



The most extreme usage of the forklift truck includes frequent driving between low temperature freezer and warm warehouse areas with high humidity. In such usage, heavy condensation, formation of ice and corrosion can occur. It is preferable that when low temperature freezer forklift trucks are not used, they are kept in an area where the temperature is between 30°F (-1°C) and 23°F (-5°C) and the humidity is low.

Cold storage applications require well-trained forklift truck drivers and regular forklift truck maintenance.

### COLD STORAGE MODIFICATIONS

When preparing the forklift truck for cold storage conditioning, the number of modifications should be kept to a minimum.

- Water drainage is already considered in the standard chassis design.
- Some preconditioning and painting of the components will be used.
- All hinges, axles, and bearings are surface treated or equipped with grease fittings.
- Replacement of the hydraulic oil is not required in Cooler (High Temperature Freezer Truck) in some cold storage applications.

## 8.4 CARE IN SEVERE DUST OR LINT CONDITIONS

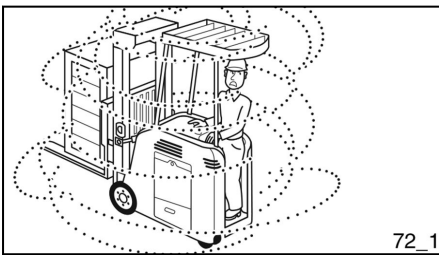

For operating the forklift truck in severe dust or lint conditions, consult your dealer.

## Chapter 9 Maintenance

### 9.1 GENERAL



Taking proper care of your forklift truck is a vital part of the overall planned maintenance program.

Your participation in this program will provide an early warning to help identify potential maintenance problems.

Do-it-yourself maintenance does not include repairs. If your forklift truck requires any repairs, contact your authorized dealer. The mechanics of Mitsubishi forklift truck dealers are well trained and know how to safely make repairs.

#### **⚠ WARNING**

- Make sure the service area is safe.
- Follow the recommended safe procedures.
- Use only the right tools for the job.
- Park the forklift truck on a level surface with the forks lowered, multi-function control handle in NEUTRAL and battery disconnected.
- All repairs must be made by authorized personnel.

**Follow these rules to save yourself and others from injury and to service your forklift truck properly.**

#### **⚠ WARNING**

Should the forklift truck become unsafe during operation in any way whatsoever, you must report it immediately to the designated authority. The forklift truck must not be used again until it has been restored to safe operational condition.

#### **⚠ WARNING**

##### **Lines, Tubes, and Hoses**

- Leaks could cause fires. Contact your authorized dealer for repair or replacement.
- DO NOT bend or strike high pressure lines. Check lines, tubes, and hoses carefully.
- DO NOT install bent or damaged lines, tubes, or hoses.
- Repair loose or damaged oil lines, tubes, or hoses.
- DO NOT use your bare hands to check for leaks, use a board or cardboard.
- Tighten connections to the recommended torque.
- Make sure all clamps, guards, and heat shields are installed correctly to reduce the risk of vibration, rubbing against other parts, and excessive heat during operation.

**If any of the following is found on a part, replace the part.**

- End fittings damaged or leaking
- Outer covering chafed or cut and wire reinforcing exposed
- Outer covering ballooning locally
- Evidence of kinked or crushed hose
- Metal embedded in the outer cover
- End fittings displaced

**⚠ WARNING**

**BE SURE to perform inspections.**

- If you fail to perform required inspections, it could lead to accidents.
- Operate the forklift truck at a reduced speed during inspections. An accident could be caused if operated at normal speed and the forklift truck is faulty.
- Dress properly for the job. **DO NOT** wear loose clothing or accessories such as flapping cuffs, dangling chains, neckties, scarves, or rings that could catch in moving parts.
- Wear personal protective equipment appropriate for the conditions of your work places.

**⚠ WARNING**

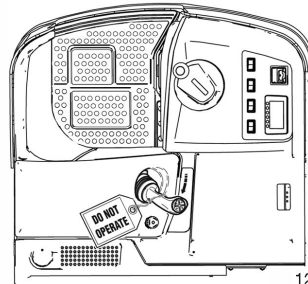

If your forklift truck requires any repair, attach a "DO NOT OPERATE" or similar warning tag to the steering wheel or multi-function control handle, remove the key, and contact your dealer.

**9.2 INSPECTION PRECAUTIONS**

You must read and understand the warnings and instructions contained in this manual before performing maintenance procedures.

**⚠ WARNING**

Turn the key switch to OFF and disconnect the battery before lubricating or performing any maintenance on the forklift truck (unless instructed otherwise in this manual or in the Service Manual).  
The recommended maintenance intervals are for the forklift truck operating under normal conditions. If operation is in adverse conditions or corrosive environments, inspect the forklift truck more frequently.

**⚠ CAUTION**

Changing the drive tires and steer tire on your forklift truck is a specialized task. If the tire or wheels need replacement contact your dealer.

**⚠ CAUTION**

- Avoid mixing lubricants. In some cases, different brands of lubricants are not compatible with each other and deteriorate when mixed. It is best to stick with the same brand at successive service intervals.
- Before refilling, clean filler holes. After filling, clean up spills.

**⚠ WARNING**

If it is necessary to make an inspection while the forklift truck is turned on, **ALWAYS USE TWO WORKERS**— one, the operator, at the controls and the other checking where the operator can see him.

**CAUTION**

A daily (Pre-Start) inspection is the key to safety. At the beginning of each shift, check your forklift truck to make sure it is in a safe operating condition. Always inspect your forklift truck under the following conditions:

- Forklift truck on a hard and level surface
- Mast in vertical position
- Forktips on ground
- All motors stopped
- Parking brake applied
- Control levers (switches) in the NEUTRAL position
- Wheels blocked.

**CAUTION**

Contact your authorized dealer for the proper disposal of wastes accumulated after replacement of tires, batteries, oils, and fluids.

**9.3 MAINTENANCE SCHEDULE**

**9.3.1 MAINTENANCE SCHEDULE - OVERVIEW**

As the operator, you are responsible for the performance of a pre-start inspection "Every 10 Service Hours or Daily." You are also responsible for those items listed under "Every 50 Service Hours or Weekly" (whichever comes first) in the Maintenance Intervals Chart to keep your forklift truck in proper working condition.

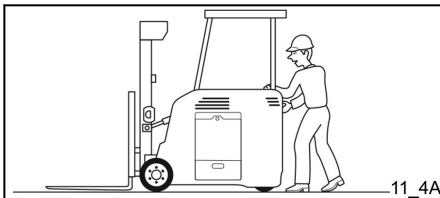

For periodic inspection and periodic change of parts, however, rely on the expert knowledge of the factory-trained servicemen, and the service facilities at your dealer's workshop.

<b>Periodic Inspection Time Intervals</b>	One month (30 days) or 200 service hours after delivery of a new forklift truck, (whichever comes first)
	Every 1000 hours or 6 months (whichever comes first)
	Every 2000 hours or 1 year (whichever comes first)

**NOTE:** Periodic inspection time intervals stated above are based on normal operating conditions. They must be reduced accordingly if the forklift truck is used in conditions of extreme dust, temperature, fluctuations, multiple shifts and so on. Contact your authorized dealer.

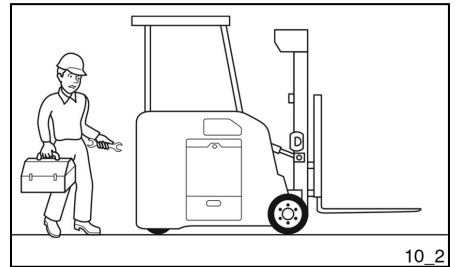

Your pre-start inspection duties (Every 10 Service Hours or Daily) are covered in the remainder of this section.

**9.3.2 PRE-START INSPECTION**

**WARNING**



Fill out a pre-start inspection sheet. Remember, a complete and thorough pre-start inspection is the best insurance against personal injury and property damage.

**9.3.3 SERVICE INTERVALS**

**9.3.3.1 EVERY 10 HOURS OR DAILY**

<b>Component Group</b>	<b>Item</b>	<b>Service</b>
General	Damage or faulty operation found the day before, Page 9-5	Check
	Loose Components and Hardware, Page 9-7	Check
	Decals and Warning Labels, Page 9-7	Check
	Fire Extinguisher (if equipped), Page 9-7	Check
	Ventilation Slots, Page 9-7	Check
	Operator Compartment, Page 9-7	Check
Hydraulic System	Hydraulic Connections, Page 9-6	Check
	Hydraulic Reservoir, Page 9-6	Check
Electrical	Battery, Page 9-5	Check
	Battery Connector & Emergency Power Off (EPO), Page 9-5	Check
	Battery Gates, Page 9-5	Check
	Lights (if equipped), Page 9-6	Check
	Switches, Page 9-6	Check
	Horn, Page 9-6	Check
Frame and Chassis	Optional Warning Devices (if equipped), Page 9-7	Check
	Static Strap (if equipped), Page 9-6	Check
Driving System	Overhead Guard, Page 9-6	Check
	Function Controls on multi-function control handle, Page 9-6	Check
	Steering, Page 9-7	Check
	Operator Presence Pedal (Brakes), Page 9-5	Check
Mast and Forks	Traction Pedal, Page 9-5	Check
	Mast, Page 9-6	Check
	Lift Chains, Page 9-6	Check
Wheel	Forks, Page 9-6	Check
	Steer Tire, Drive Tires, Page 9-6	Check

**9.3.3.2 EVERY 50 HOURS OR WEEKLY**

<b>Component Group</b>	<b>Item</b>	<b>Service</b>
Electrical	Battery, Page 9-7	Clean
	Cables/Hoses, Page 9-7	Inspect
Mast and Forks	Mast, Page 9-7	Lubricate
	Forks, Page 9-7	Inspect

**9.3.3.3 ONE MONTH OR 200 SERVICE HOURS AFTER DELIVERY OF FORKLIFT TRUCK**

<b>Component Group</b>	<b>Item</b>	<b>Service</b>
Electrical	Battery, Page 9-7	Check Specific Gravity
General	Loose Hardware, Page 9-7	Check
Driving System	Drive Axles, Page 9-7	Change Oil

**9.3.3.4 EVERY 1000 SERVICE HOURS OR 6 MONTHS, WHICHEVER COMES FIRST**

<b>Component Group</b>	<b>Item</b>	<b>Service</b>
Hydraulic System	Hydraulic Reservoir, Page 9-8	Change Filter
Driving System	Drive Axles, Page 9-8	Check Oil Level
Electrical	Contactors Tips, Page 9-7	Check
General	Loose Hardware, Page 9-8	Check
Mast and Forks	Mast, Page 9-7	Lubricate

**9.3.3.5 EVERY 2000 SERVICE HOURS OR 12 MONTHS, WHICHEVER COMES FIRST**

<b>Component Group</b>	<b>Item</b>	<b>Service</b>
Hydraulic System	Hydraulic Reservoir, Page 9-8	Change Filter & Fluid
Driving System	Drive Axles, Page 9-8	Change Oil

**9.4 EVERY 10 SERVICE HOURS OR DAILY (PRE-START), WHICHEVER COMES FIRST**

**Damage or Faulty Operation Found the Day Before**

- Have the repairs been made properly?
- Check the daily inspection list.

**1. Battery**

- Was battery fully charged before start of shift?
- Was water level checked after charging?
- Check for leakage—look for battery acid on floor.
- Is the battery weight within the range specified on the battery size label decal?
- Battery weight must meet minimum requirements listed on the forklift truck capacity plate.

**2. Battery Connector and Emergency Power Off (EPO) Switch**

- Battery cables and connector are in good condition.
- Battery connector makes a solid electrical connection between battery and the forklift truck.
- EPO switch powers down forklift truck when you press the switch.

**3. Battery Gates**

- Are battery gates properly installed and securely locked into place.

**4a. Operator Presence Pedal (Brakes)**

- Does operator presence pedal operate smoothly with no binding?
- Does it stop the forklift truck within specific limits?
- Does it disable the travel function when pedal is released?

**4b. Traction Pedal**

- Does traction pedal operate smoothly with no binding?

- Does it disable the travel function when pedal is released?

**7. Mast**

- Check to ensure there is no damage to hoses and limit switches.
- Check inside channels for lubrication.
- Is there any indication of leaks from the cylinders or hydraulic lines?
- Does the mast move up and down smoothly when you operate the multi-function control handle?
- Does the mast tilt forward and backward smoothly when you operate the tilt function on the multi-function control handle?
- Is the load backrest extension properly secured to the mast?
- Inspect the load backrest extension for cracks and distortions. (Special attention should be given to all welds).
- Shake the backrest extension to check for excessive rattle.
- Are lift and lower stops installed and in good condition?

**8. Lift Chains**

- Inspect lift chains for lubrication and visible damage.
- Are lift chains properly lubricated?
- Are lift chains adjusted to the correct length?
- Inspect chains for proper tension and position.
- Are lift chains equal in tension?
- Check by pushing the chains midway.
- If the chains are loose or the tension is not equal, have the chains adjusted.

**11. Forks**

- Are the fork stopper pins properly engaged?

**12. Function Controls on multi-function control handle**

- Does the multi-function control handle move smoothly, without binding?

- Does it move to neutral when it is released?

- Does the forklift truck go forward or backward when the multi-function control handle is moved toward its respective function?
- Does the mast lift and lower when you operate the lift and lower functions of the multi-function control handle?
- Does the mast tilt forward and backward when you operate the tilt function on the multi-function control handle?

**13. Horn**

- Does the horn sound when you press the horn button?

**14. Hydraulic Connections**

- Check all hydraulic connections to cylinders and hoses.
- Check floor around and under forklift truck for hydraulic oil leaks.

**15. Hydraulic Reservoir**

- Check hydraulic fluid level.

**16. Lights (if equipped)**

- Are the lights in safe working condition?
- Are the lenses clean and not defective?
- Do the lights come on illuminate when you switch them on?

**17. Switches**

- Do the switches work for each of their assigned functions?

**18. Steer Wheel, Drive Tires**

- Are the tires in good condition?
- There should be NO cracks, NO flat spots, NO missing chunks or No bond failure.
- Tires should have adequate tread.

**19. Static Strap (if equipped)**

- Is the static strap attached?

**20. Overhead Guard**

- Check the front and rear overhead guard mounting bolts on each side.

- Carefully inspect the overhead guard for cracks and distortion. (Special attention should be given to all welds).
- Contact your dealer if repairs are needed.

**21. Loose Components and Hardware**

- All guards and covers installed and secure.
- Check for damage to components.
- Check all welded components. There should be no cracks.
- Check forklift truck for loose or missing hardware. (Tighten loose hardware).

**22. Decals and Warning Labels**

- All Decals - (Warning/Safety/Operational) in place and legible.

**23. Fire Extinguisher (if equipped)**

- Is the extinguisher charged and secured?

**24. Ventilation Slots**

- Are the ventilation slots free of obstructions?

**26. Optional Warning Devices (if equipped)**

- Do all optional warning devices operate properly? Optional Warning devices include such items as:
  - Lights
  - Backup Alarms
  - Strobe Lamp

**27. Steering**

- Check the steering angle indicator by turning the steering wheel in both directions until it stops and check that the wheel position is displayed on the control panel.

**28. Operator Compartment**

- Make sure the operator compartment and the controls are clean for a safe operation.

**9.5 EVERY 50 SERVICE HOURS OR WEEKLY, WHICHEVER COMES FIRST**

**1. Battery**

- Using a soft cloth, wipe away dirt and dust from the top and sides of the battery.

**6. Cables/Hoses**

- Check to see that all electrical cables and hydraulic cables are in good condition.

**7. Mast**

- Lubricate inside mast channel.

**11. Forks**

- Inspect the forks for cracks and distortions.

\* (Special attention should be given to the heel section and all welds).

**9.6 ONE MONTH AFTER DELIVERY OF FORKLIFT TRUCK**

**1. Battery**

- Check the specific gravity of battery cells.

**21. Loose Hardware**

- Check hardware on forklift truck and retighten loose hardware.

**25. Drive Axle**

- Change drive axle oil.

**9.7 EVERY 1000 SERVICE HOURS OR 6 MONTHS, WHICHEVER COMES FIRST**

**5. Contactor Tips**

- Check for burnt contactor tips, pitting and insufficient contact material.

**7. Mast**

- Lubricate mast strips and roller surfaces (each side).
- Lubricate bracket side rollers (each side).
- Lubricate chain (each side).
- Lubricate tilt socket (each side).
- Lubricate tilt cylinder (each side).



- Lubricate main gear (thin layer around perimeter).

**15. Hydraulic Reservoir**

- Change hydraulic reservoir oil filter.

**25. Drive Axle**

- Check drive axle oil level.

**9.8 EVERY 2000 SERVICE HOURS OR 12 MONTHS, WHICHEVER COMES FIRST**

**15. Hydraulic Reservoir**

- Change hydraulic oil
- Change hydraulic oil filter

**25. Drive Axle**

- Change drive axle oil.

**9.9 READY TO OPERATE**

**9.9.1 NOW YOUR FORKLIFT TRUCK IS READY TO OPERATE**

**9.10 HYDRAULICS**

**9.10.1 HYDRAULIC OIL LEVEL (FORKLIFT TRUCK LEVEL) CHECK**

Hydraulic tank is located in the center front tractor (from the operator's position).

**⚠ WARNING**



100678A

Remember, a complete and thorough pre-start inspection is the best insurance against personal injury and property damage.

**9.10.2 CHECK THE HYDRAULIC OIL LEVEL**** WARNING**

The hydraulic oil is under pressure during operation and is hazardous to health and the environment.

- Do not touch hydraulic lines under pressure.
- Dispose of used oil according to specifications and regulations. Store used oil safely until it is disposed of in accordance with regulations.
- Avoid hydraulic oil spill.
- Remove spilled and/or escaped liquids immediately using a suitable binding agent.
- Dispose of the mixture of binding agent and consumables in compliance with applicable regulations.
- Legal requirements for handling hydraulic oil must be observed.
- Wear safety gloves when handling hydraulic oil.
- Wear safety glasses when handling hydraulic oil.
- Do not allow hydraulic oil to touch hot motor parts.
- Do not smoke when handling hydraulic oil.
- Avoid contact and consumption. If swallowed do not induce vomiting. Instead find a physician immediately.
- If you inhale oil mist or vapors, let in fresh air.
- If oil comes in contact with the skin, wash off oil with soap and water.
- If oil comes in contact with the eyes, rinse them out with water and find a physician immediately.
- Change soaked clothes and shoes immediately.

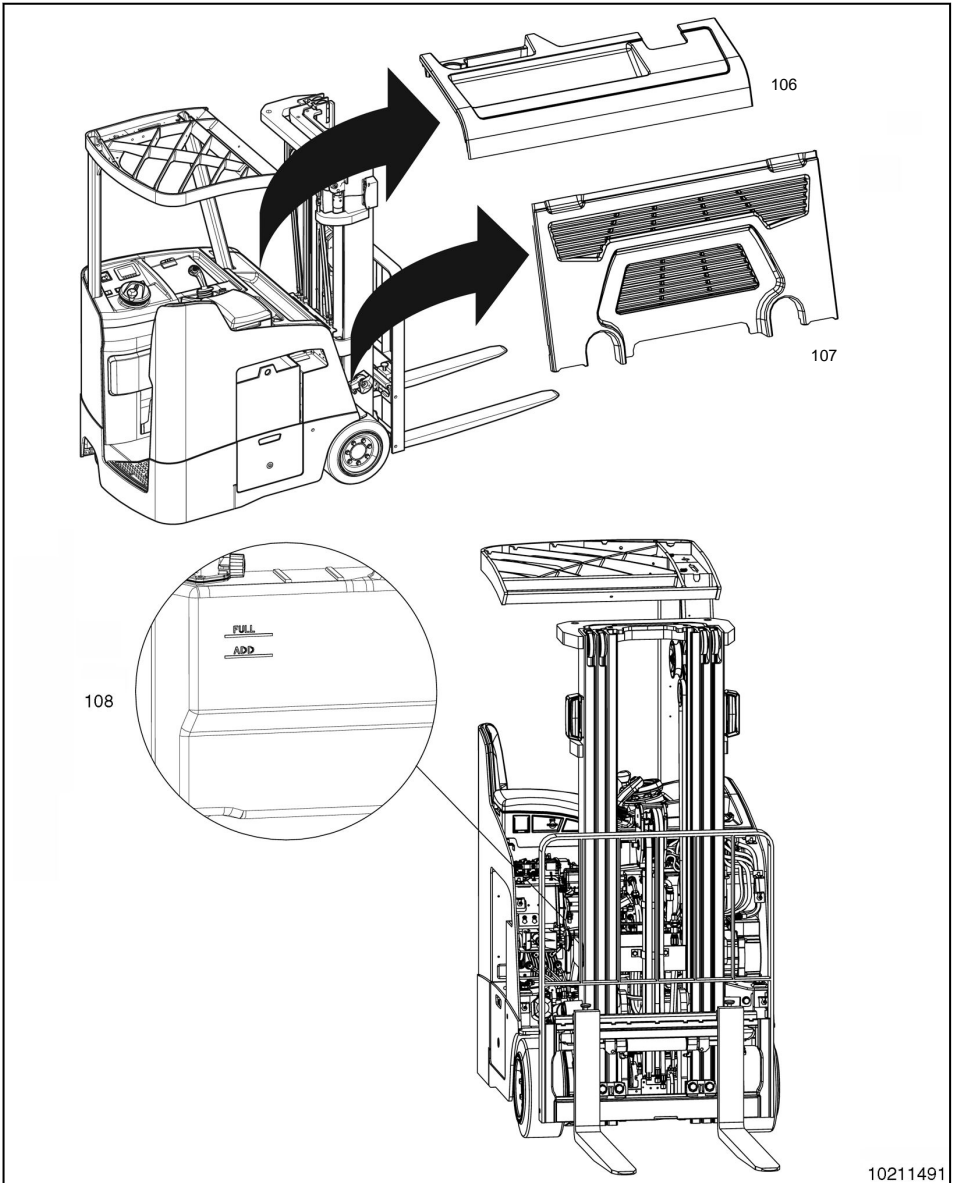

106. TOP HOOD COVER

107. LOWER HOOD COVER

108. FULL/ADD LEVEL

**NOTE:** Do not fill above the "FULL" mark.

**9.10.3 ADDING HYDRAULIC OIL**

1. Park the forklift truck on a level surface, lower the forks all the way, turn OFF the key and unplug the battery.
2. By hand, carefully pull top hood cover up to release snaplocks on both sides, then remove.
3. By hand, carefully pull lower hood towards forks to release snaplocks on both sides, then remove.
4. Remove the hydraulic tank filler cap by turning it counterclockwise.
5. Remove hydraulic oil filter from hydraulic tank.
6. Add hydraulic oil to the hydraulic tank.
7. Replace hydraulic oil filter and filler cap.
8. Replace top and lower hood covers.

**CAUTION**

When adding hydraulic oil:

- Clean the filler hole to prevent dirt from dropping into the tank.
- DO NOT overfill.
- Clean up spillage.

**9.11 BATTERY**

**9.11.1 BATTERY SPECIFIC GRAVITY CHECK**

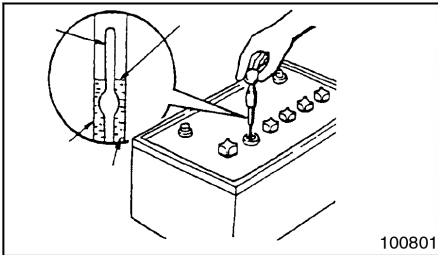

100801

Using a battery hydrometer, check the specific gravity of the battery cells. Take the reading at eye level.

Specific gravity corrected to 27°C (80°F)	Battery charge
1.265 to 1.280	Normal operating range
1.225 to 1.240	Normal discharge range (to be recharged)

Specific gravity corrected to 27°C (80°F)	Battery charge
Below 1.225 Completely discharged	<b>CAUTION</b>
	Operating the forklift truck with a battery in this state of discharge may cause permanent damage to the forklift truck components or the battery.

**9.11.2 BATTERY ELECTROLYTE LEVEL CHECK**

Not required if battery type is a maintenance free battery.

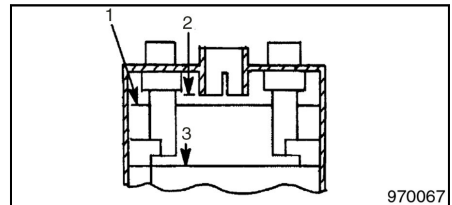

970067

1. HIGH LEVEL
2. BOTTOM OF VENT WELL
3. LOW LEVEL

Is the electrolyte level maintained between the UPPER LEVEL and LOWER LEVEL specified by the battery manufacturer?

1. If the electrolyte level is low, remove the filler caps and add distilled water to the cells. Before removing the caps, clean the top of the battery.
2. After adding the water, tighten the caps securely.

**WARNING**

If acid gets in your eyes, FLUSH THEM IMMEDIATELY WITH LARGE AMOUNTS OF WATER AND SEE A DOCTOR AT ONCE.

### 9.11.3 REMOVING OR INSTALLING BATTERY GATES

- Keep your hand away from the pinch points when installing the battery gates.
- Check the horizontal movement of the battery and adjust to 1/2 inch (13mm) or less.

#### 9.11.3.1 REMOVING BATTERY GATE

1. Loosen the retaining screw (117) on the battery gate (116).

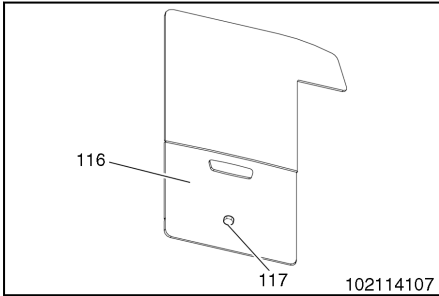

2. Remove the battery covering plate.

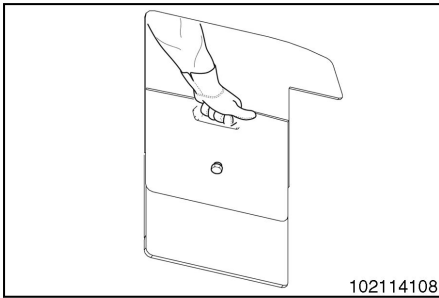

#### 9.11.3.2 INSTALLING BATTERY GATE

1. Install the battery covering plate.

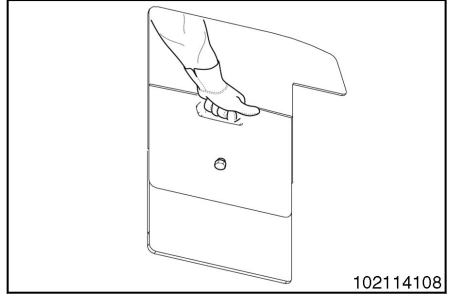

2. Tighten the retaining screw (117) on the battery gate (116).

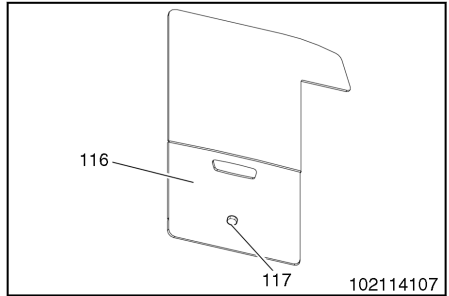

### 9.11.4 REMOVING THE BATTERY

When performing maintenance or changing the battery always remove one of the battery gates, usually the battery gate on the side where the battery connector is located.

Follow these steps when removing a battery from a forklift truck that has battery gates:

1. Park the forklift truck on level ground, push the EPO button in and remove key.
2. Make sure both battery gates are properly installed.
3. Before removing the battery gate, usually the battery gate on the side where the battery connector is located make sure the opposite battery gate is locked in place.
4. Pull up on the battery gate handle and set the battery gate aside.
5. Disconnect the battery and then remove the battery.

6. Using a battery stand or equivalent material handling equipment, slide the battery out of the open end of the battery compartment.
7. Make sure the removed battery is properly stored.

**⚠ WARNING**

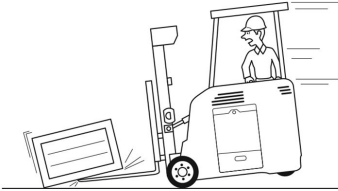

19\_4

Never operate the forklift truck without the correct size and weight of battery in the forklift truck.

**⚠ WARNING**

Never use chain or other items for lifting a battery that is not specifically designed for the task.

When removing a battery from a forklift truck, always use a battery stand or equivalent material handling equipment.

If acid gets in your eyes, FLUSH THEM IMMEDIATELY WITH LARGE AMOUNTS OF WATER AND SEE A DOCTOR AT ONCE.

### 9.11.5 INSTALLING THE BATTERY

**⚠ CAUTION**

**Crushing may result in damage to the battery cable.**

Crushing may occur when inserting the battery if the battery cable is inserted without a cable guide.

- Always install the battery with a cable guide.
- Contact the manufacturer's service department when replacing the factory-fitted battery.

**NOTE:** A battery extraction device and Allen key will be need to perform this procedure.

**NOTE:** Installation is the reverse order. When reinstalling the battery, note the proper installation position and make sure the battery is connected correctly.

1. Tighten the retaining screw (105) and lock nut (105) or handle on the battery lock (104).
2. Connect the battery to the forklift truck plug.
3. Install battery gate.

**⚠ WARNING**

Take precautions not to jam or cut the battery cables during installation of the battery as this may result in a short that could cause a fire or battery explosion.

When installing a battery, always be sure that it is fully charged before placing the forklift truck into operation.

**⚠ WARNING**

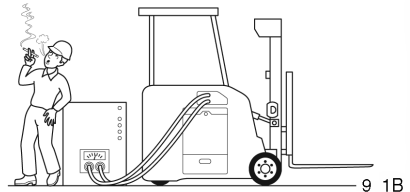

9\_1B

Always charge the battery in a well-ventilated area. DO NOT smoke, and keep any type of flame away from equipment. DO NOT use equipment in this area that is liable to produce sparks.

### 9.11.6 CHARGING THE BATTERY

- Make sure the correct charger is used for the battery you are using.
- Check
  - Voltage of charger.
  - Voltage of battery.
  - Size or power output of charger is correct.
- Type of Charge

- Daily charge.  
This should be done every day and normally takes eight hours to fully charge a battery.
  - Equalizing charge.  
This charges the battery at a slow rate and balances the charge in all the cells. This should normally be done once per week. The most accurate check of specific gravity is obtained after the equalizing charge is complete.
- Check the battery charge
- Use a hydrometer.
  - Complete the pre-start inspection procedure.

**⚠ WARNING**

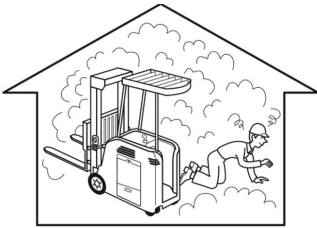

11\_1

Explosive gases are generated when batteries are being charged. Always ensure adequate ventilation for battery charging. Do not smoke, keep flames and sparks away.

**⚠ CAUTION**

- Always turn off charger before connecting or disconnecting the battery.
- Always check the water level before charging to make sure the plates are covered.
- Never overfill before charging. The electrolyte will expand during charging and may overflow.
- After charging, add water to the battery manufacturer's full mark.
- Do not plug a battery charger into the forklift truck. This severely damages the forklift truck's electrical systems.

## Chapter 10 Service Data

### 10.1 REFILL CAPACITIES

REFILL CAPACITIES	ITEM	QUANTITY
Liters (approx. U.S. gallons)	Drive Axle Boxes (per side)	1.0 liter (0.26 gallon)
Liters (approx. U.S. gallons)	Hydraulic System	19.0 liters (5.01 gallons)

### 10.2 BATTERY COMPARTMENT DIMENSIONS

Is the battery weight within the range specified on the battery size label decal? The battery type must meet minimum requirements listed on the forklift truck capacity chart name plate.

#### Standard Battery Compartment Dimensions and Battery Weight Ranges (lbs.)

BATTERY COMPARTMENT LIMITS							
MODEL		MAX. LENGTH	MAX. WIDTH	MAX. HEIGHT	MAX. WEIGHT		
ET0214	FBCS14N	ECS14N	STD.	362	14.25		
			OPT.	413	16.25		
ET0216	FBCS16N	ECS16N	STD.	413	16.25	960	38.5 805 31.6
			OPT.	464	18.25		
ET0318	FBCS18N	ECS18N	STD.	540	21.25		

THE BATTERY LENGTH AND WIDTH MUST BE 13mm (0.5") SMALLER FOR INSTALLATION AND REMOVAL CLEARANCE.

MACHINES RATED UL TYPE EE MUST UTILIZE ENCLOSED AND LOCKABLE BATTERY ENCLOSURE.

SIDE BATTERY SET SCREW MUST BE TIGHTENED AGAINST THE BATTERY TO ELIMINATE LATERAL BATTERY MOVEMENT. MINIMUM BATTERY WEIGHT MUST BE RETAILED FOR PROPER MACHINE STABILITY.

ENG J4081-00500

Model		Length in. (mm)	Width in. (mm)	Height in. (mm)	Minimum Battery Weight lbs. (kg)	Maximum Battery Weight lbs. (kg)
FBCS14N	Standard	14.25 (363)	38.6 (980)	31.7 (805)	1600 (727)	1900 (864)
FBCS14N	Option	16.25 (413)	38.6 (980)	31.7 (805)	2000 (909)	2300 (1045)
FBCS14N	Option	18.25 (464)	38.6 (980)	31.7 (805)	2300 (1045)	2600 (1182)
FBCS16N	Standard	16.25 (413)	38.6 (980)	31.7 (805)	2000 (909)	2300 (1045)
FBCS16N	Option	18.25 (464)	38.6 (980)	31.7 (805)	2300 (1045)	2600 (1182)
FBCS18N	Standard	21.25 (540)	38.6 (980)	31.7 (805)	2600 (1182)	2900 (1318)



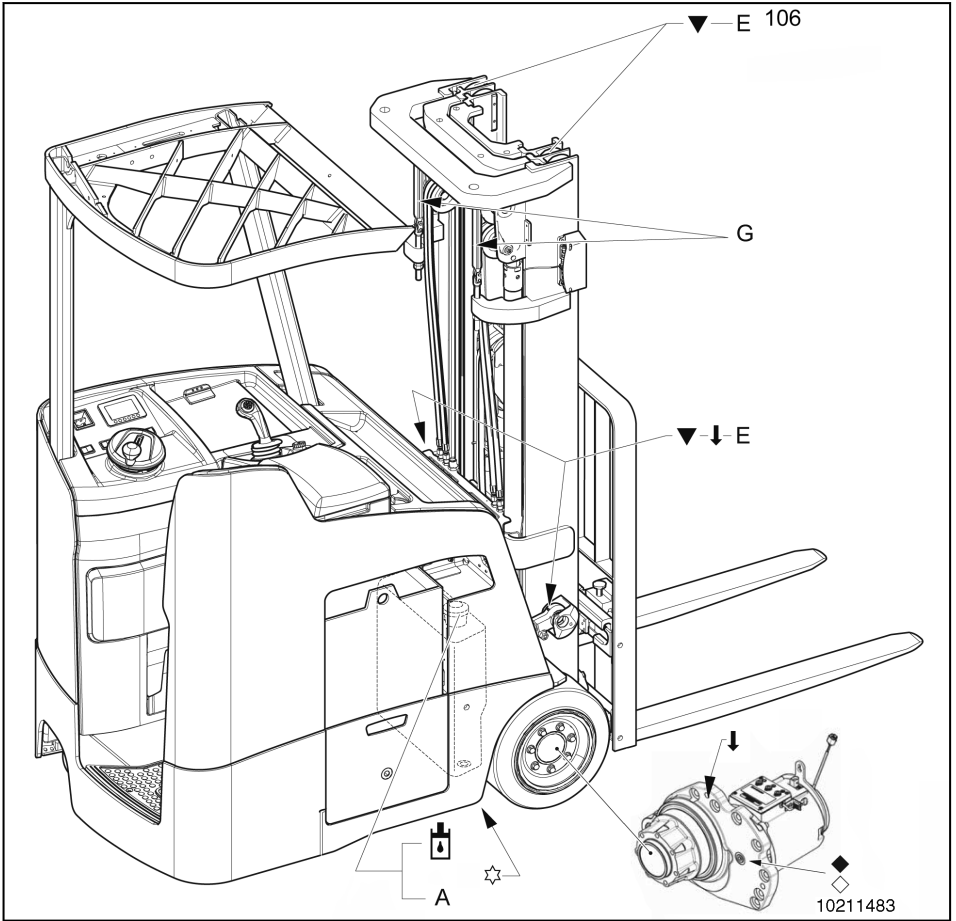

10.3 LUBRICATION CHART



Part	Lubricant		Period (Hours)
	Freezer Application	Normal	
Hydraulic System	1	2	2000
Gearbox Oil	3	4	2000
Grease Points	5	5	1000
Grease Mast Channels	6	6	2000
Chains	7	7	1000

**NOTE:** For lubrication instructions see **LOCATION OF WARNING AND SAFETY DECALS.**

106	Mast (both sides)		Hydraulic oil filler neck
◇	Drain plug		Hydraulic oil drain plug
▼	Sliding surfaces	◆	Transmission oil filler neck
↓	Lubrication point	◇	Drain plug

### 10.4 FLUIDS

**NOTE:** Use fluids according to lubrication instructions.

**NOTE:** \*Forklift trucks are factory-equipped with a special hydraulic oil (hydraulic oil as indicated by a blue coloration) or Plantosyn 46 HVI biodegradable hydraulic oil. Hydraulic oil is available only from the service department. The use of named alternative hydraulic oils is not prohibited but may lead to a decline in functionality. Hydraulic oil may be mixed with one of the named alternative hydraulic oils.

Grease Reference Values					
Code	Thickener Type	Dropping point °C (°F) ASTM D2265	Working penetration at 25 °C (77 °F)	NLG1 class	Operating temperature °C (°F)
E	Lithium-Complex	280	265 - 295	2	-35/+120 H (-31/+248)
H		(536)	(509 - 563)		

### 10.5 ELECTRICAL FUSES

#### 10.5.1 CHECKING THE ELECTRICAL FUSES

**⚠ WARNING**

To reduce the risk of fire, replace with the same DC fuse type and rating.

1. Remove hood.
2. Check the fuses ratings (109) against the table and replace if necessary.

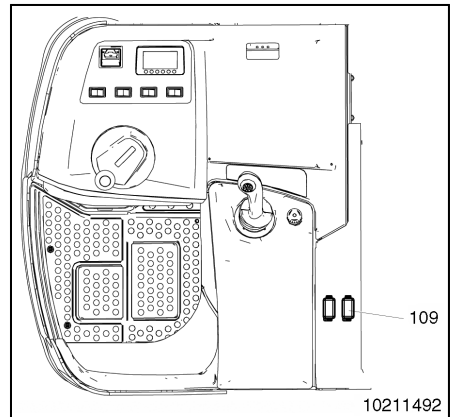

**Fuse ratings**

STANDARD					
2F16	5A/58V	4F7	2A/58V	6F6	2A/58V
1F13	5A/58V	F4	2A/58V	4F8	2A/58V
F25	2A/58V	5F11	2A/58V	1F12	2A/58V
OPTIONS					
6F9	2A/58V	5F1	2A/58V	5F7	2A/58V
5F2.2	10A/58V	5F2.1	10A/58V	6F9	2A/58V
				5F2.3	10A/58V

**10.6 USAGE CONDITIONS**

**Environmental Temperature**

Ambient temperature during operation should be -28°C (-18°F) to +40°C (+104°F).

**NOTE:** During constant use when there are extreme temperature fluctuations and relative humidity condensation, special equipment and approval is required for forklift trucks.  
 During constant use under 5°C (41°F), special modification and approval is required for forklift trucks.

## 10.7 FORKLIFT TRUCK WEIGHTS

Model	FBCS14N	FBCS16N
Service weight without battery	3181 kg (6999 lb)	3211 kg (7065 lb)
Service weight with maximum weight battery, no load	4045 kg (8899 lb)	4257 kg (9365 lb)
Service weight with minimum weight battery, no load	3908 kg (8599 lb)	4120 kg (9065 lb)

Model	FBCS18N
Service weight without battery	3291 kg (7241 lb)
Service weight with maximum weight battery, no load	4609 kg (10141 lb)
Service weight with minimum weight battery, no load	4473 kg (9841 lb)
Axle loading with maximum battery weight, rated load, front (drive)	5503 kg (12107 lb)
Axle loading with maximum battery weight, rated load, rear (steer)	831 kg (1828 lb)
Axle loading with maximum battery weight, no load, front (drive)	2262 kg (4977 lb)
Axle loading with maximum battery weight, no load, rear (steer)	2236 kg (4919 lb)

## Chapter 11 To the Mitsubishi Forklift Truck Owner

### 11.1 INSTRUCTIONS FOR ORDERING PARTS

Depending on the manufacturer of the mast, the mast model number is located on either the right or left outer mast upright.

#### Chassis nameplate

Each forklift truck has a nameplate. It tells you the:

- Forklift truck serial number
- Forklift truck model designation

- Forklift truck weight without battery and with maximum weight battery
- Machine capacity
- Lifting height

(Example)

My forklift truck serial number is XXXXXXXX.  
For quick reference, record your forklift truck's serial number in the space provided. It can be found on the Manufacturer Name Plate or the Capacity Name Plate.

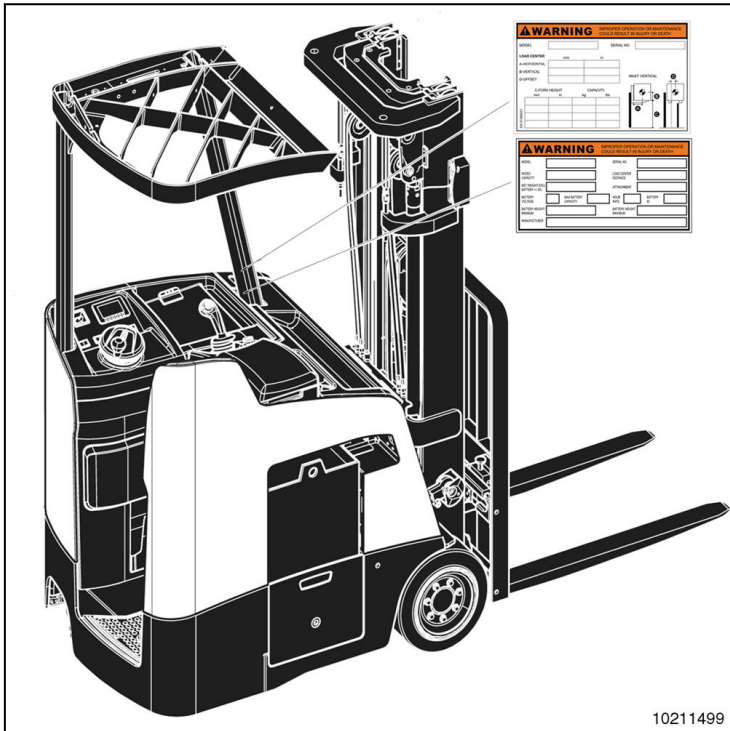

The forklift truck serial number can also be found stamped on the inside of the front mini door, right side, under the battery connector.

S/N \_\_\_\_\_

**11.2 TO THE MITSUBISHI FORKLIFT TRUCK OWNER**

Truck model, Serial No.	Drive Motor, Serial No.
Mast model, Serial No.	Attachment model, Serial No.
Delivering Dealer	Name
	Address
	Delivery Date

Fill out this sheet for your ready reference.

**11.3 TRANSFER OF OWNERSHIP REPORT FOR MITSUBISHI CUSTOMERS ONLY**

Please help us ensure that we always have the current owner on file. If the forklift truck is sold, please submit the following information to the MCFA address provided below.

<b>TRANSFER REPORT</b> TRANSFER OF OWNERSHIP REPORT						DATE	
DISTRIBUTED BY:  Mitsubishi Caterpillar Forklift America Inc. 2121 W. Sam Houston Parkway N. Houston, Texas 77043-2305 Email: lift.central@mcfa.com Attn: Marketing Services		MODEL	SERIAL NUMBER		HOUR METER		
<b>TRANSFERRED FROM</b>							
DEALER / CUSTOMER NAME				ADDRESS			
CITY / TOWN		COUNTY	STATE	ZIP	COUNTRY		
<b>TRANSFERRED TO</b>							
CUSTOMER NAME				ADDRESS			
CITY / TOWN		COUNTY	STATE	ZIP	COUNTRY		
CUSTOMER'S PRINCIPAL BUSINESS				CUSTOMER CONTACT			
(AREA CODE) TELEPHONE NUMBER (       )				(AREA CODE) TELEFAX NUMBER (       )			
_____ CUSTOMER'S SIGNATURE				_____ DATE			
Copies distributed to: <input type="checkbox"/> Dealer Sales Department <input type="checkbox"/> Dealer Service Department / Warranty <input type="checkbox"/> MCFA Marketing Services Email: lift.central@mcfa.com							
500014M							